

CR 155

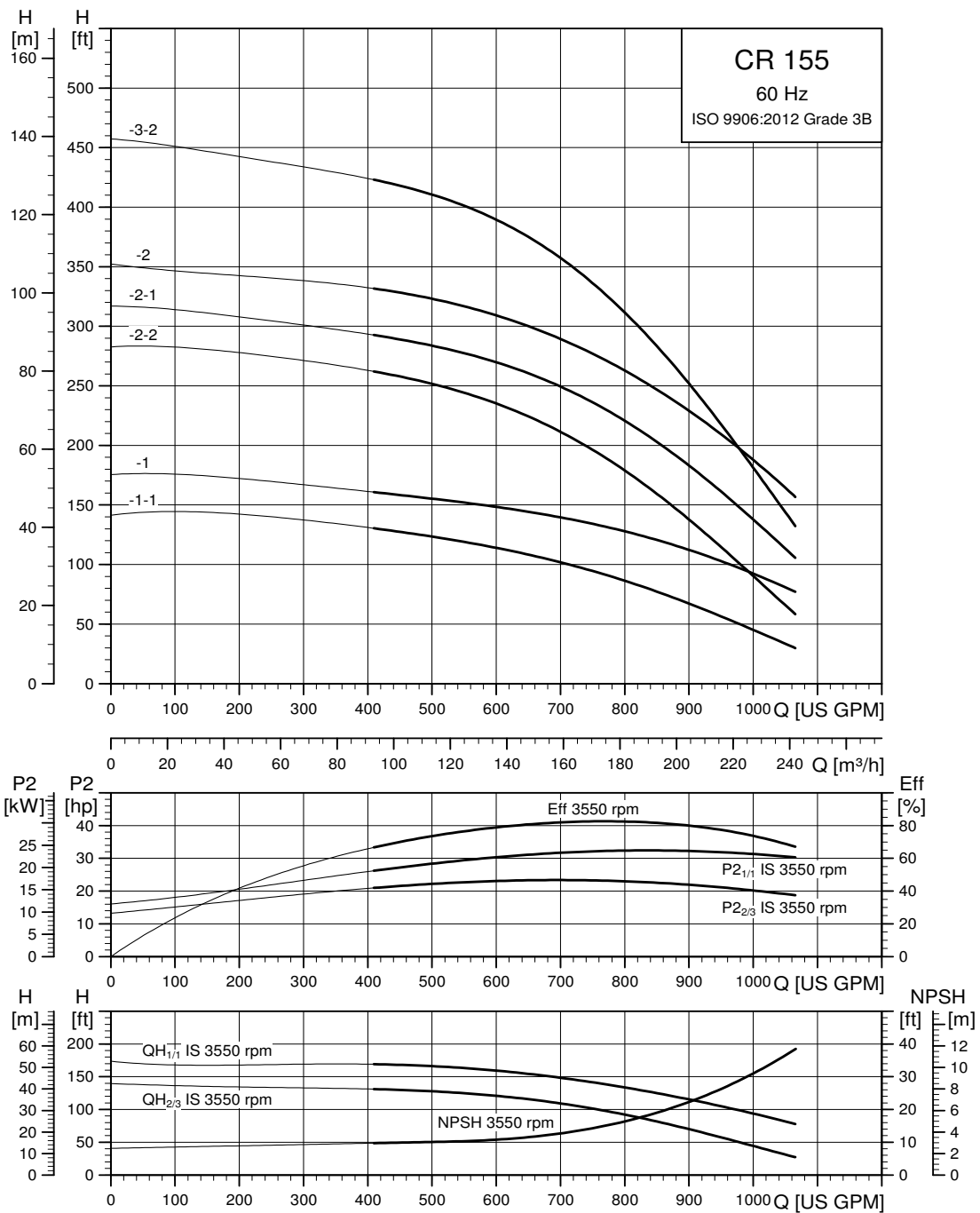

The maximum pump efficiency (Eta) is based on a three-stage pump.

TM06 5541 3718

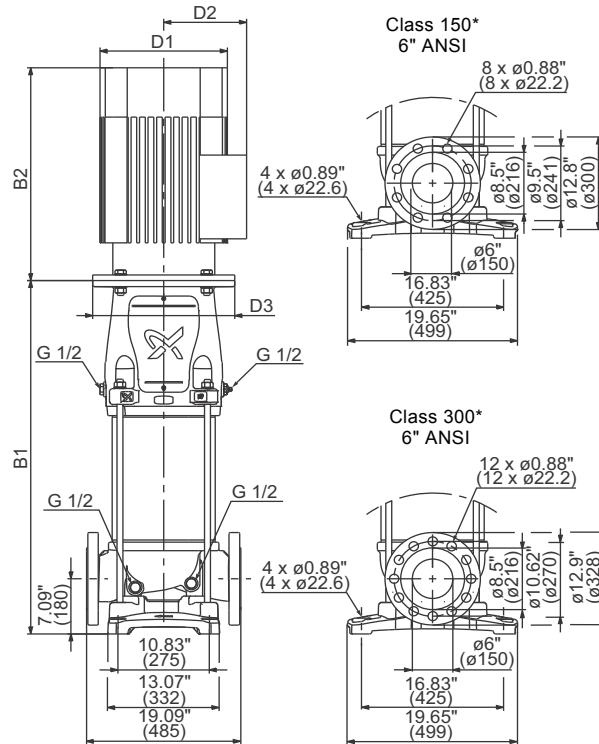

TM06 6061 0218

* CR, CRN 155 pumps with 1 to 3 stages (with 1 reduced diameter impeller) are fitted with 150 lb. (68 kg) flanges as standard. 300 lb. (136 kg) flanges are available on request.
CR, CRN 155 pumps with 3 or more full diameter impellers are fitted with 300 lb. (136 kg) flanges as standard.

Dimensions and weights

Pump type	Motor P ₂ [Hp (kW)]	Dimension [inch (mm)]					Net weight [lbs (kg)]
		B1	B1+B2	D1	D2	D3	
CR 155-1-1	25 (18)	30.9 (785)	53.7 (1363)	12.4 (314)	8 (204)	10.5 (267)	520 (236)
CR 155-1	40 (30)	31.8 (808)	59.4 (1508)	16.9 (429)	14.1 (359)	12.5 (318)	798 (362)
CR 155-2-2	50 (37)	36.6 (930)	64.2 (1630)	16.9 (429)	14.1 (359)	12.5 (318)	888 (403)
CR 155-2-1	60 (45)	36.6 (930)	63.7 (1617)	16.9 (429)	14.1 (359)	12.5 (318)	939 (426)
CR 155-2	75 (56)	36.6 (930)	64.2 (1630)	19.7 (500)	18.1 (460)	12.5 (318)	1259 (571)
CR 155-3-2	75 (56)	41.4 (1052)	69 (1752)	19.7 (500)	18.1 (460)	12.5 (318)	1283 (582)

CRN 155

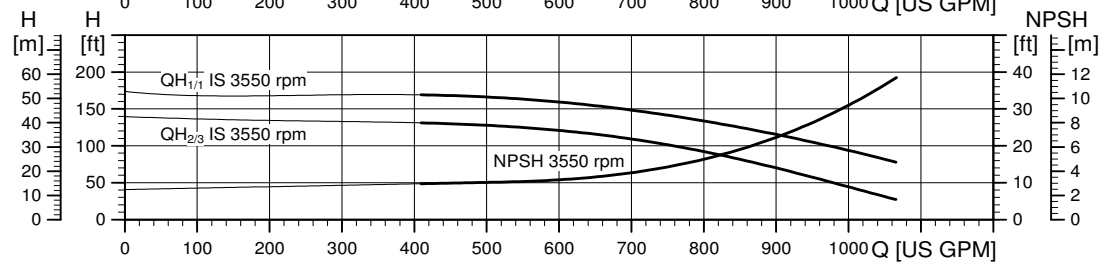
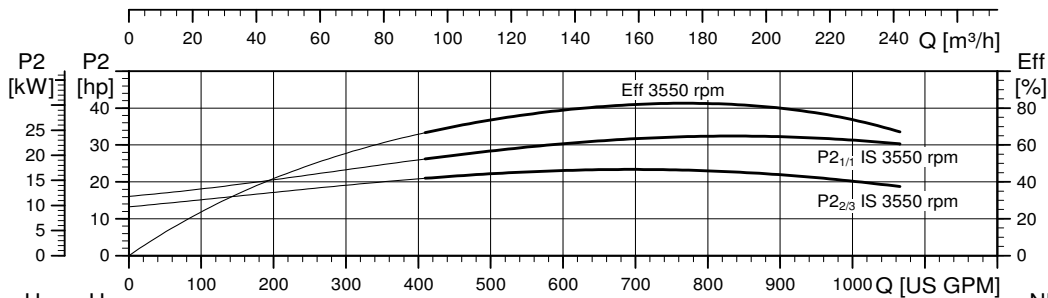
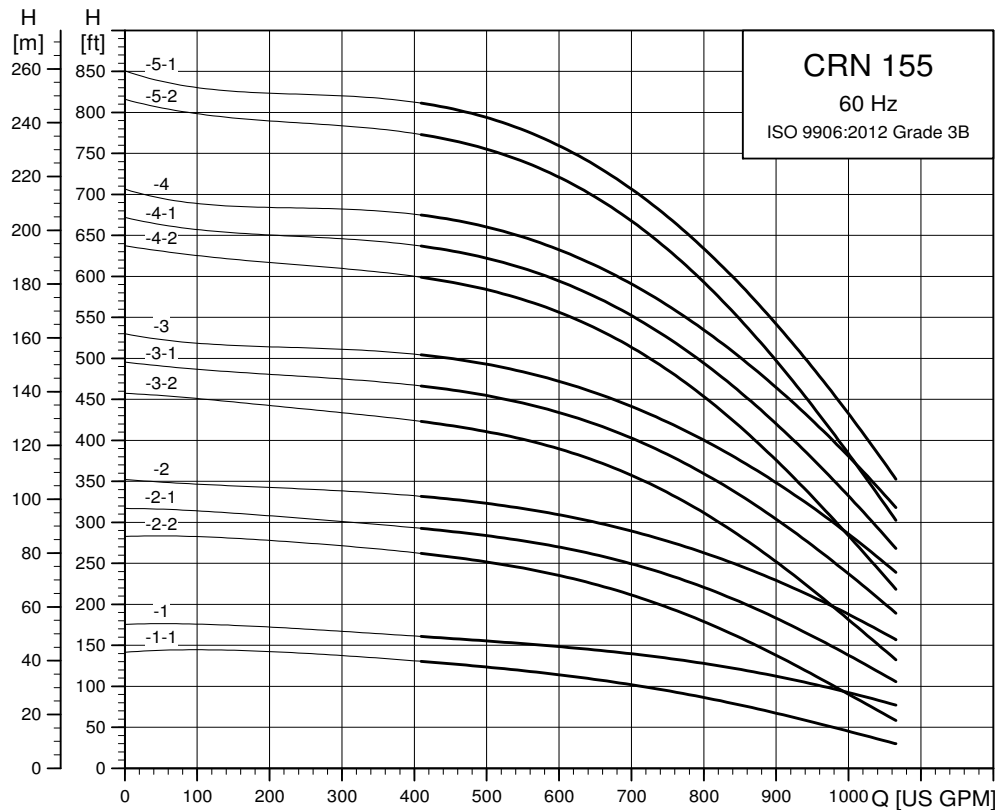

The maximum pump efficiency (Eta) is based on a three-stage pump.

TM06 5542 3718

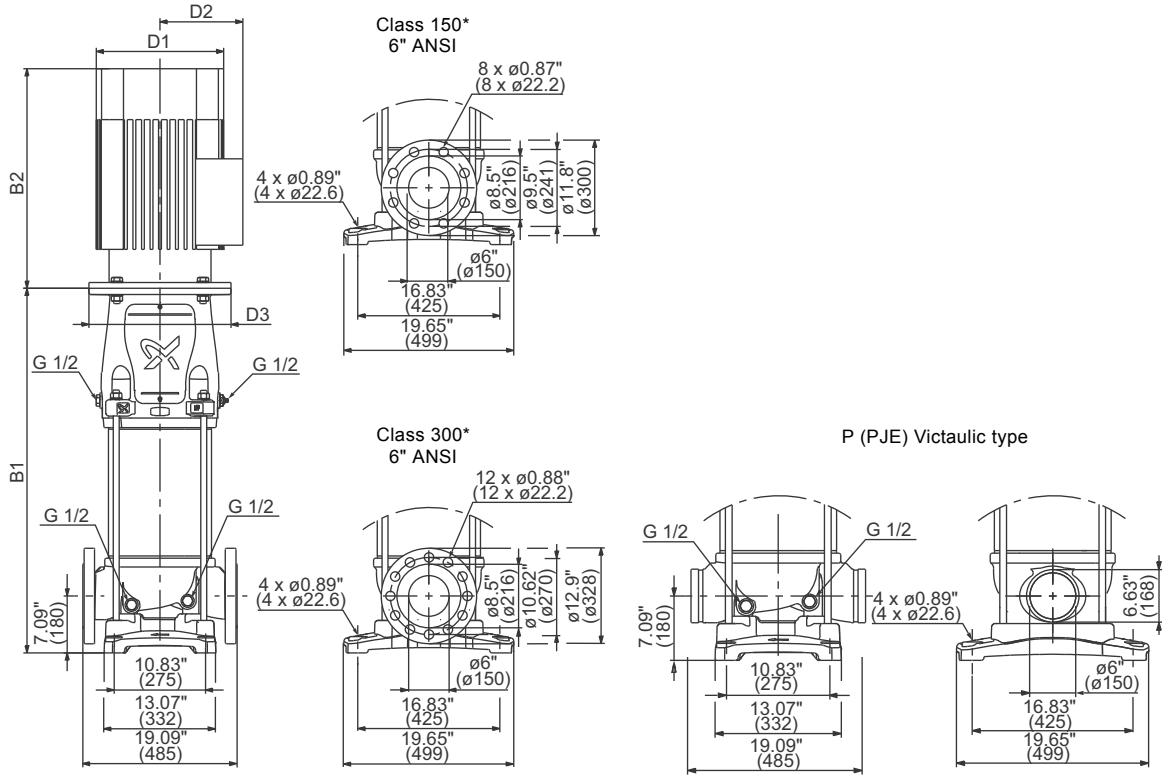

TM06 6062 0218

* CR, CRN 155 pumps with 1 to 3 stages (with 1 reduced diameter impeller) are fitted with 150 lb. (68 kg) flanges as standard. 300 lb. (136 kg) flanges are available on request.
CR, CRN 155 pumps with 3 or more full diameter impellers are fitted with 300 lb. (136 kg) flanges as standard.

Dimensions and weights

Pump type	Motor P ₂ [Hp (kW)]	Dimension [inch (mm)]					Net weight [lbs (kg)]
		B1	B1+B2	D1	D2	D3	
CRN 155-1-1	25 (18)	30.9 (785)	53.7 (1363)	12.4 (314)	8 (204)	10.5 (267)	520 (236)
CRN 155-1	40 (30)	31.8 (808)	59.4 (1508)	16.9 (429)	14.1 (359)	12.5 (318)	798 (362)
CRN 155-2-2	50 (37)	36.6 (930)	64.2 (1630)	16.9 (429)	14.1 (359)	12.5 (318)	888 (403)
CRN 155-2-1	60 (45)	36.6 (930)	63.7 (1617)	16.9 (429)	14.1 (359)	12.5 (318)	939 (426)
CRN 155-2	75 (56)	36.6 (930)	64.2 (1630)	19.7 (500)	18.1 (460)	12.5 (318)	1259 (571)
CRN 155-3-2	75 (56)	41.4 (1052)	69 (1752)	19.7 (500)	18.1 (460)	12.5 (318)	1283 (582)
CRN 155-3-1	100 (75)	41.3 (1050)	77.4 (1965)	22.2 (565)	19.2 (488)	18 (457)	1761 (799)
CRN 155-3	100 (75)	41.3 (1050)	77.4 (1965)	22.2 (565)	19.2 (488)	18 (457)	1761 (799)
CRN 155-4-2	125 (93)	46.1 (1172)	85.7 (2178)	26.5 (673)	22.7 (576)	18 (457)	2238 (1015)
CRN 155-4-1	125 (93)	46.1 (1172)	85.7 (2178)	26.5 (673)	22.7 (576)	18 (457)	2238 (1015)
CRN 155-4	125 (93)	46.1 (1172)	85.7 (2178)	26.5 (673)	22.7 (576)	18 (457)	2238 (1015)
CRN 155-5-2	150 (112)	50.9 (1294)	90.6 (2300)	26.5 (673)	22.7 (576)	18 (457)	2493 (1131)
CRN 155-5-1	150 (112)	50.9 (1294)	90.6 (2300)	26.5 (673)	22.7 (576)	18 (457)	2493 (1131)