

PARTS LIST		SEWAGE & WASTEWATER PUMPS				12/13/2021
ITEM	PART No.	DESCRIPTION	QTY	SIZE	MATERIAL	NOTES
1	001-938-25	Cable Set (32') (USA)	1	2PNCT4Cx5.5mm2	KR-2	
2	140-055-10	Hex.Bolt	4	M8x25	SUS304	
3	142-163-18	Spring Washer	4	M8	SUS304	
4	070-107-18	Cable Clamp	1		FC	Included in ITEM #1 Cable Ass'y
5	140-035-14	Hex.Bolt	2	M6x20	SUS304	Included in ITEM #1 Cable Ass'y
6	006-126-14	Stuffing Box	1	No.2	FC	Included in ITEM #1 Cable Ass'y
7	008-143-13	Mould Cover	1	KR2-8	CR	Included in ITEM #1 Cable Ass'y
8	143-085-21	Pan Screw (w/Spring Washer)	1	M4x6	SWRM	
9	009-130-10	Terminal	1	R-5.5-4	CU	Included in ITEM #1 Cable Ass'y
10	009-276-19	Compression type Terminal	3	TMNB-5.5(Insulated)		Included in ITEM #1 Cable Ass'y
11	072-107-14	Eye Bolt	2	M16	SS	can substitute 072-107-27 (SUS304)
	142-399-15	Washer		d17xd29x0.1t	SUS304	
	142-400-10	Washer		d17xd29x0.3t	SUS304	
12	140-098-15	Hex.Bolt	4	M12x35	SUS304	
13	142-165-10	Spring Washer	4	M12	SUS304	
14	050-000-79	Motor Bracket	1		FC	
15	122-173-19	O-Ring	1	V-225(222.5xd6)	NBR	*
16	142-000-08	Wave Washer	1	6306B(d71xd59x4.0t)	SK5	
17	052-000-25	Bearing (w/O-ring)	1	AC-6306ZZC3		
18	058-000-09	Lead Wire Protection Plate	1	d86xd224x1.6t	SPHC	
19	143-126-12	Pan Screw (w/Spring Washer/Plain Washer)	2	M4x12	SWRM	
20	053-456-12	Motor Protector 208/230V-60HZ(USA)	1	KA314-HLBL00	(H.C)	
	053-485-10	Motor Protector 460V-60HZ(USA)	1	KA314-HKXL00	(H.C)	
	053-485-10	Motor Protector 575V-60HZ(USA)	1	KA314-HKXL00	(H.C)	
21	055-000-68	Rotor	1Set			
22	147-067-16	Impeller Key	1	10x8x32L	SUS420	
23	056-C01-19	Stator 208/230V-60HZ(USA)	1Set			
	056-C02-10	Stator 460V-60HZ(USA)	1Set			
	056-C05-13	Stator 575V-60HZ(USA)	1Set			
24	064-000-12	Motor Frame	1		FC	
25	140-100-11	Hex.Bolt	4	M12x45	SUS304	
26	142-165-10	Spring Washer	4	M12	SUS304	
27	122-173-19	O-Ring	1	V-225(222.5xd6)	NBR	*
28	140-032-37	Hex.Bolt	3	M6x15	SWRM	
29	062-223-16	Bearing Fixing Plate	1	d92xd130x4.5t	SS	
30	052-112-10	Bearing	1	6309ZZC3		
31	146-027-11	Retaining Ring	1	C45	SK5	
32	140-104-15	Hex.Bolt	4	M12x65	SUS304	
33	142-165-10	Spring Washer	4	M12	SUS304	
34	060-430-12	Bearing Housing	1		FC	

PARTS LIST		SEWAGE & WASTEWATER PUMPS				12/13/2021
ITEM	PART No.	DESCRIPTION	QTY	SIZE	MATERIAL	NOTES
35	121-247-12	Packing	2	d12.3xd18x2t	PE	*
36	035-113-18	Oil Plug	2	M12x14	SUS304	
37	140-099-16	Hex.Bolt	2	M12x40	SUS304	
38	142-165-10	Spring Washer	2	M12	SUS304	
39	025-000-97	Mechanical Seal	1	H-35	SIC	
40	143-070-23	Pan Screw	2	M5x6	SWRM	
41	030-156-18	Oil Lifter	1	H-35(A)(T)	Resin	
42	143-070-10	Pan Screw	3	M5x6	SWRM	
43	030-150-12	Seal Stopper	1	H-35(A)(T)	SPCC	
44	122-159-19	O-Ring	1	G-280(279.3xd5.7)	NBR	*
45	029-187-14	Oil Casing	1	100-5.5/7.5-4B2	FC	
46	122-159-19	O-Ring	1	G-280(279.3xd5.7)	NBR	*
47	026-115-12	Oil Seal	1	TC-608212	NBR	
48	021B5519	Impeller (60Hz)	1	150B47.5L-64	FC	
49	144-530-16	Hex.Socket Set Screw	2	M6x15	SUS304	
50	142-202-10	Impeller Fixing Washer	1	d13xd50x15t	SUS304	
51	142-000-22	Spring Washer	1	M12(CP)	SUS304	
52	140-304-17	Hex.Socket Cap Bolt	1	M12x45	SUS304	
53	046-107-13	Air Release Valve	1	PT-1/2	Nylon	
54	020-689-14	Pump Casing	1	200-11-4B3	FC	
55	120-173-13	Packing (S.Cover)		d321xd348x0.5t	PE	
56	022-536-11	Suction Cover	1	200-11-4B2	FC	
57	142-165-10	Spring Washer	6	M12	SUS304	
58	140-097-14	Hex.Bolt	6	M12x30	SUS304	
	173-001-16	Packing O-Ring Set	1Set	(Marked by *)		
15	122-173-19	O-Ring (M.Bracket/M.Frame)	1	V-225(222.5xd6)	NBR	*
27	122-173-19	O-Ring (M.Frame/Brg.Housing)	1	V-225(222.5xd6)	NBR	*
35	121-247-12	Packing (Oil Plug)	2	d12.3xd18x2t	PE	*
44	122-159-19	O-Ring (Brg.Housing/O.Casing)	1	G-280(279.3xd5.7)	NBR	*
46	122-159-19	O-Ring (O.Casing/P.Casing)	1	G-280(279.3xd5.7)	NBR	*
		Lubricant		Turbine Oil VG32 5,200ml		
	183-013-19	Impeller Puller	1	BE No.13 2"	SGPSS	19200

PARTS LIST		SEWAGE & WASTEWATER PUMPS			12/13/2021	
ITEM	PART No.	DESCRIPTION	QTY	SIZE	MATERIAL	NOTES

EXPLODED VIEW

150B47.5L-64

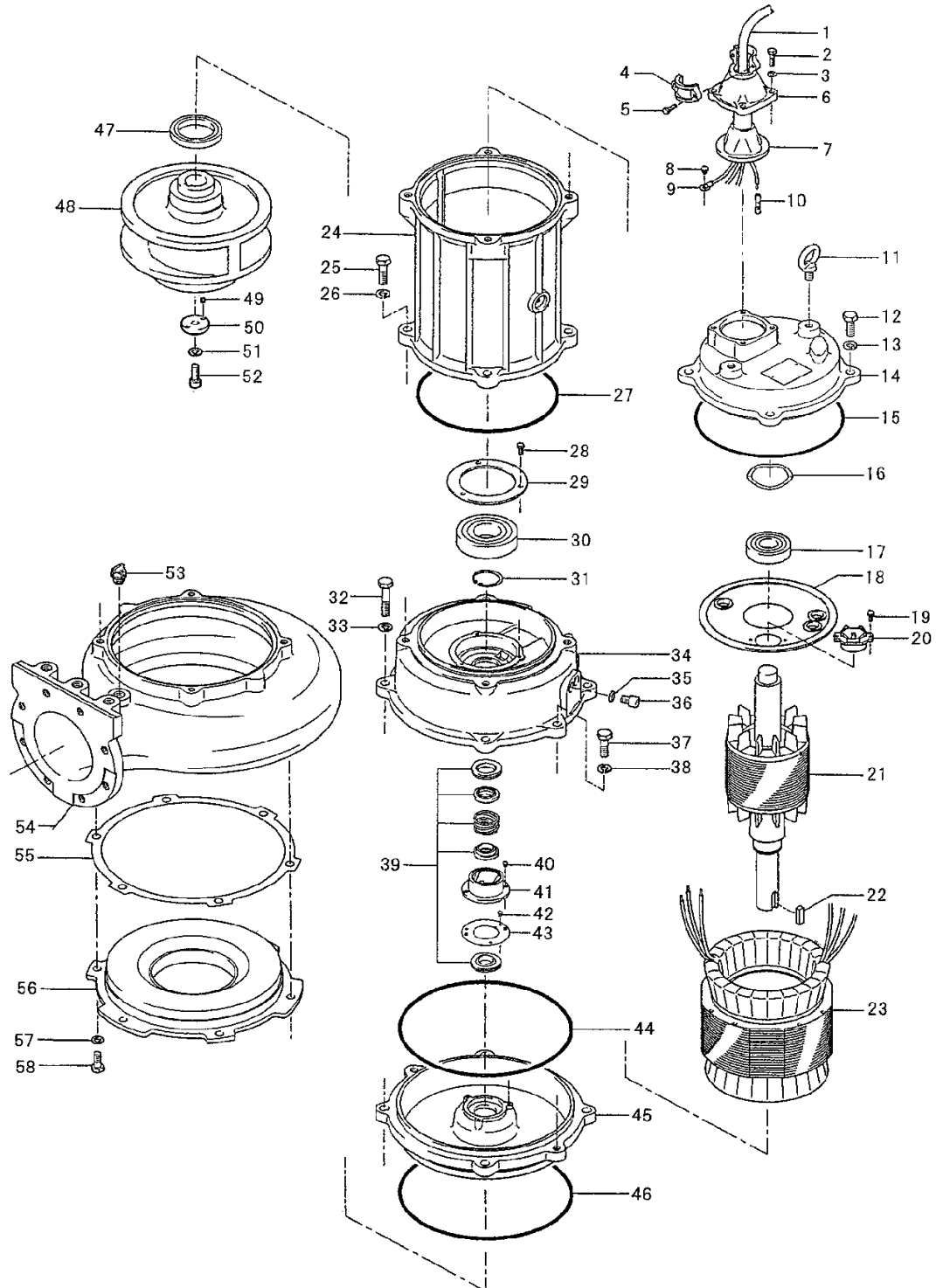

C-01237-2