



INTRODUCTION

Thank you for purchasing a Honda engine. We want to help you to get the best results from your new engine and to operate it safely. This manual contains information on how to do that; please read it carefully before operating the engine. If a problem should arise, or if you have any questions about your engine, consult an authorized Honda servicing dealer.

All information in this publication is based on the latest product information available at the time of printing. Honda Motor Co., Ltd. reserves the right to make changes at any time without notice and without incurring any obligation. No part of this publication may be reproduced without written permission.

This manual should be considered a permanent part of the engine and should remain with the engine if resold.

Review the instructions provided with the equipment powered by this engine for any additional information regarding engine startup, shutdown, operation, adjustments or any special maintenance instructions.

United States, Puerto Rico, and U.S. Virgin Islands:
We suggest you read the warranty policy to fully understand its coverage and your responsibilities of ownership. The warranty policy is a separate document that should have been given to you by your dealer.

SAFETY MESSAGES

Your safety and the safety of others are very important. We have provided important safety messages in this manual and on the engine. Please read these messages carefully.

A safety message alerts you to potential hazards that could hurt you or others. Each safety message is preceded by a safety alert symbol  and one of three words, DANGER, WARNING, or CAUTION.

These signal words mean:

 **DANGER** You WILL be KILLED or SERIOUSLY HURT if you don't follow instructions.

 **WARNING** You CAN be KILLED or SERIOUSLY HURT if you don't follow instructions.

 **CAUTION** You CAN be HURT if you don't follow instructions.

Each message tells you what the hazard is, what can happen, and what you can do to avoid or reduce injury.

DAMAGE PREVENTION MESSAGES

You will also see other important messages that are preceded by the word NOTICE.

This word means:
 **NOTICE** Your engine or other property can be damaged if you don't follow instructions.

The purpose of these messages is to help prevent damage to your engine, other property, or the environment.

© 2007 Honda Motor Co., Ltd. — All Rights Reserved
GX610R1-GX620R1-GX670R-GX610U1-GX620U1-GX670U

37Z6C602
00X37-Z6C-6021

HONDA

OWNER'S MANUAL MANUEL DE L'UTILISATEUR MANUAL DEL PROPIETARIO

GX610 · GX620 · GX670

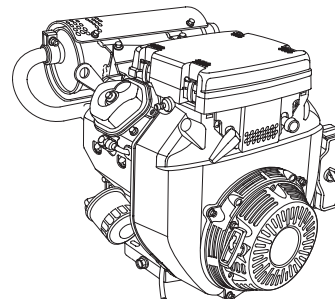

WARNING:

The engine exhaust from this product contains chemicals known to the State of California to cause cancer, birth defects or other reproductive harm.

ENGLISH

FRANÇAIS

ESPAÑOL

CONTENTS

INTRODUCTION.....1	SPARK PLUG.....10
SAFETY MESSAGES.....1	SPARK ARRESTER.....11
SAFETY INFORMATION.....2	HELPFUL TIPS & SUGGESTIONS.....11
SAFETY LABEL LOCATION.....2	STORING YOUR ENGINE.....11
COMPONENT & CONTROL LOCATION.....2	TRANSPORTING.....12
FEATURES.....3	TAKING CARE OF UNEXPECTED PROBLEMS.....13
BEFORE OPERATION CHECKS.....3	FUSE REPLACEMENT.....13
OPERATION.....4	TECHNICAL INFORMATION...14
SAFE OPERATING PRECAUTIONS.....4	Serial Number Location.....14
STARTING THE ENGINE.....4	Battery Connections for Electric Starter.....14
STOPPING THE ENGINE.....5	Remote Control Linkage.....15
SETTING ENGINE SPEED.....5	Carburetor Modifications for High Altitude Operation.....15
SERVICING YOUR ENGINE.....6	Emission Control System Information.....16
THE IMPORTANCE OF MAINTENANCE SAFETY.....6	Air Index.....17
SAFETY PRECAUTIONS.....6	Specifications.....17
MAINTENANCE SCHEDULE.....6	Tuneup Specifications.....18
REFUELING.....7	Quick Reference Information.....18
ENGINE OIL.....7	Wiring Diagrams.....18
Recommended Oil.....7	CONSUMER INFORMATION..19
Oil Level Check.....7	DISTRIBUTOR/DEALER LOCATOR INFORMATION..19
Oil Change.....8	CUSTOMER SERVICE INFORMATION.....19
OIL FILTER.....8	
AIR CLEANER.....9	
Inspection.....9	
Cleaning.....9	
FUEL FILTER.....10	



SAFETY INFORMATION

- Understand the operation of all controls and learn how to stop the engine quickly in case of emergency. Make sure the operator receives adequate instruction before operating the equipment.
- Do not allow children to operate the engine. Keep children and pets away from the area of operation.
- Your engine's exhaust contains poisonous carbon monoxide. Do not run the engine without adequate ventilation, and never run the engine indoors.
- The engine and exhaust become very hot during operation. Keep the engine at least 1 meter (3 feet) away from buildings and other equipment during operation. Keep flammable materials away, and do not place anything on the engine while it is running.

SAFETY LABEL LOCATION

This label warns you of potential hazards that can cause serious injury. Read it carefully. If the label comes off or becomes hard to read, contact your Honda dealer for replacement.



For Canadian types only: French label comes with the engine.

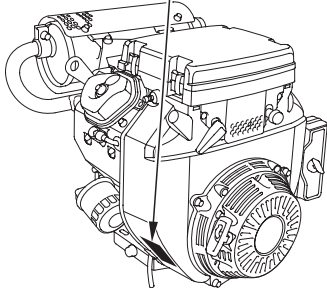

Gasoline is highly flammable and explosive. Turn engine off and let cool before refueling.



The engine emits toxic poisonous carbon monoxide gas. Do not run in an enclosed area.



Read Owner's Manual before operation.

COMPONENT & CONTROL LOCATION

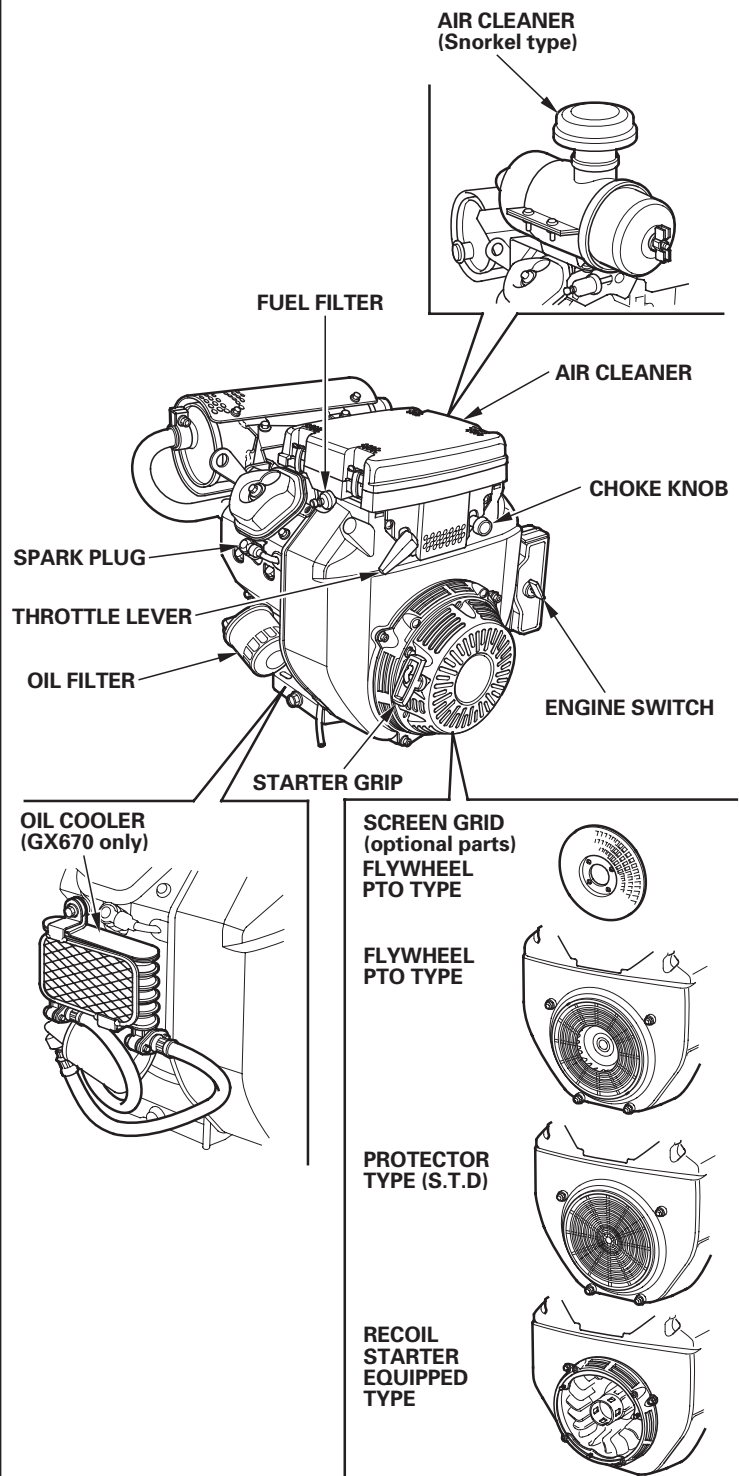

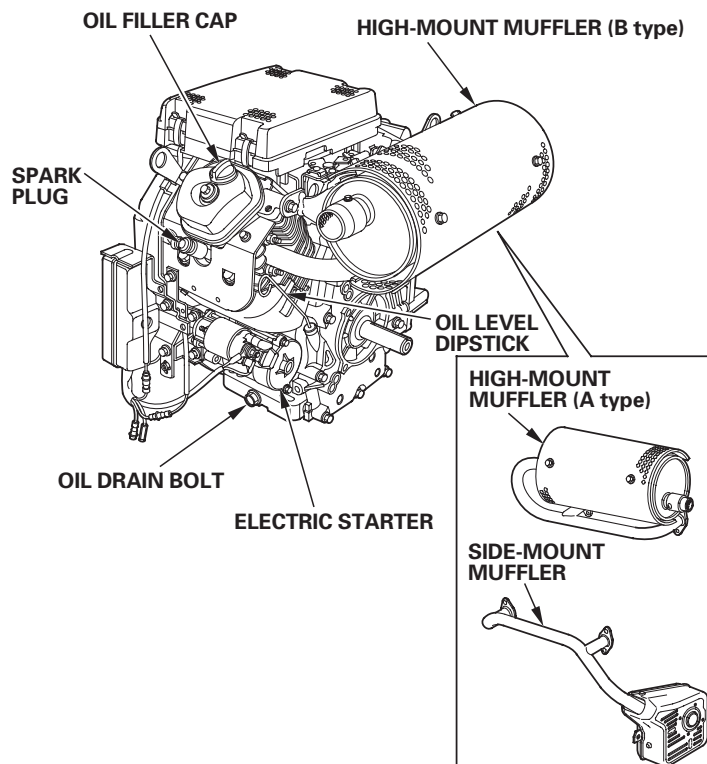

FEATURES

Oil Alert® System (applicable types)

“Oil Alert is a registered trademark in the United States”

The Oil Alert system is designed to prevent engine damage caused by an insufficient amount of oil in the crankcase. Before the oil level in the crankcase can fall below a safe limit, the Oil Alert system will automatically stop the engine (the engine switch will remain in the ON position).

If the engine stops and will not restart, check the engine oil level (see page 7) before troubleshooting in other areas.

Fuel-cut Solenoid

The engine is equipped with a fuel-cut solenoid that allows fuel to flow to the carburetor main jet when the engine switch is in the ON or START position and stops the flow of fuel to the main jet when the engine switch is in the OFF position.

The engine must be connected to the battery to energize the fuel-cut solenoid, allowing the engine to run. If the battery is disconnected, fuel flow to the carburetor main jet will stop.

Oil Cooler (GX670)

The GX670 engine is equipped with an oil cooler to maintain the correct temperature.

BEFORE OPERATION CHECKS

IS YOUR ENGINE READY TO GO?

For your safety, and to maximize the service life of your equipment, it is very important to take a few moments before you operate the engine to check its condition. Be sure to take care of any problem you find, or have your servicing dealer correct it, before you operate the engine.

⚠ WARNING

Improperly maintaining this engine, or failure to correct a problem before operation, can cause a malfunction in which you can be seriously hurt or killed.

Always perform a pre-operation inspection before each operation, and correct any problem.

Before beginning your pre-operation checks, be sure the engine is level and the engine switch is in the OFF position.

Always check the following items before you start the engine:

Check the General Condition of the Engine

1. Look around and underneath the engine for signs of oil or gasoline leaks.
2. Remove any excessive dirt or debris, especially around the muffler and recoil starter.
3. Look for signs of damage.
4. Check that all shields and covers are in place, and all nuts, bolts, and screws are tightened.

Check the Engine

1. Check the fuel level. Starting with a full tank will help to eliminate or reduce operating interruptions for refueling.
2. Check the engine oil level (see page 7). Running the engine with a low oil level can cause engine damage.

The Oil Alert system (applicable types) will automatically stop the engine before the oil level falls below safe limits. However, to avoid the inconvenience of an unexpected shutdown, always check the engine oil level before startup.

3. Check the air filter element (see page 9). A dirty air filter element will restrict air flow to the carburetor, reducing engine performance.
4. Check the equipment powered by this engine.

Review the instructions provided with the equipment powered by this engine for any precautions and procedures that should be followed before engine startup.

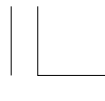

OPERATION

SAFE OPERATING PRECAUTIONS

Before operating the engine for the first time, please review the *SAFETY INFORMATION* section on page 2 and the *BEFORE OPERATION CHECKS* on page 3.

For your safety, do not operate the engine in an enclosed area such as a garage. Your engine's exhaust contains poisonous carbon monoxide gas that can collect rapidly in an enclosed area and cause illness or death.

⚠ WARNING

Exhaust contains poisonous carbon monoxide gas that can build up to dangerous levels in closed areas. Breathing carbon monoxide can cause unconsciousness or death.

Never run the engine in a closed, or even partly closed area where people may be present.

Review the instructions provided with the equipment powered by this engine for any safety precautions that should be observed with engine startup, shutdown or operation.

STARTING THE ENGINE

1. If the fuel tank is equipped with a valve, be sure the fuel valve is in the OPEN or ON position before attempting to start the engine.
2. To start a cold engine, pull the choke knob out to the CLOSED position.

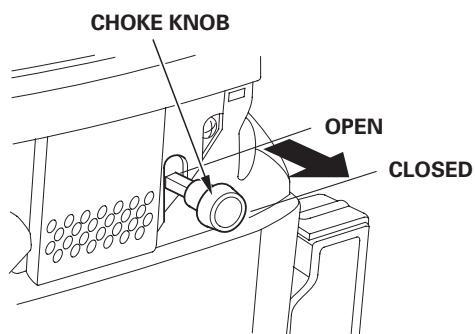

To restart a warm engine, leave the choke lever in the OPEN position.

Some engine applications use a remote-mounted choke control rather than the engine-mounted choke lever shown here. Refer to the instructions provided by the equipment manufacturer.

3. Move the throttle lever away from the MIN. position, about 1/3 of the way toward the MAX. position.

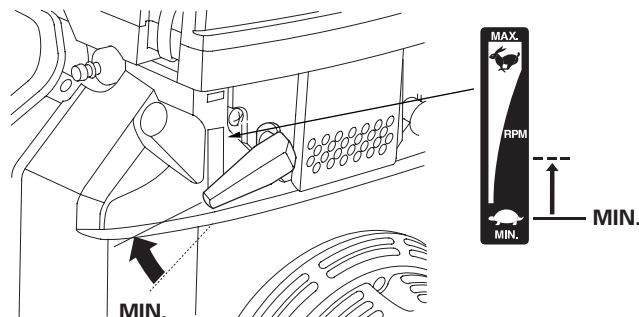

Some engine applications use a remote-mounted throttle control rather than the engine-mounted throttle lever shown here. Refer to the instructions provided by the equipment manufacturer.

4. Turn the engine switch to the ON position.

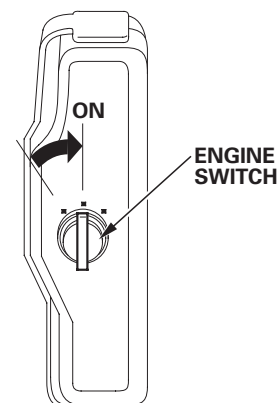
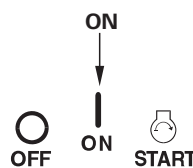

5. Operate the starter.

ELECTRIC STARTER:

Turn the key to the START position, and hold it there until the engine starts.

If the engine fails to start within 5 seconds, release the key, and wait at least 10 seconds before operating the starter again.

NOTICE

Using the electric starter for more than 5 seconds at a time will overheat the starter motor and can damage it.

When the engine starts, release the key, allowing it to return to the ON position.

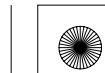
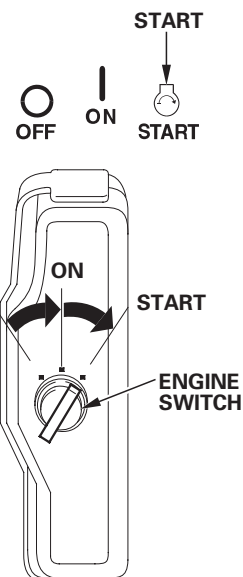

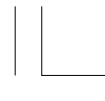

RECOIL STARTER (applicable types):

Pull the starter grip lightly until you feel resistance, then pull briskly in the direction of the arrow as shown below. Return the starter grip gently.

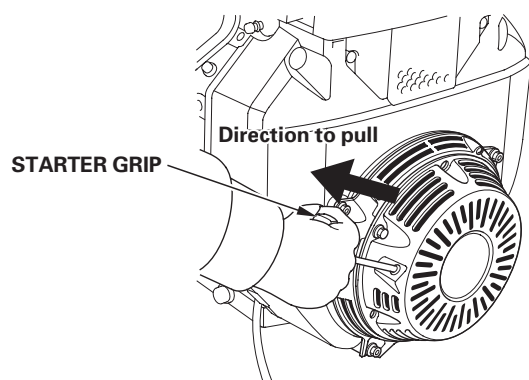

NOTICE

Do not allow the starter grip to snap back against the engine. Return it gently to prevent damage to the starter.

6. If the choke knob has been pulled to the CLOSED position to start the engine, gradually push it to the OPEN position as the engine warms up.

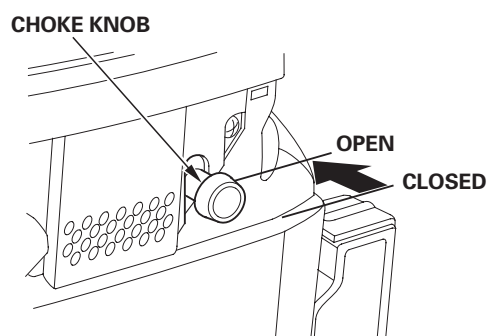

STOPPING THE ENGINE

To stop the engine in an emergency, simply turn the engine switch to the OFF position. Under normal conditions, use the following procedure. Refer to the instructions provided by the equipment manufacturer.

1. Move the throttle lever to the MIN. position.

Some engine applications use a remote-mounted throttle control rather than the engine-mounted throttle lever shown here.

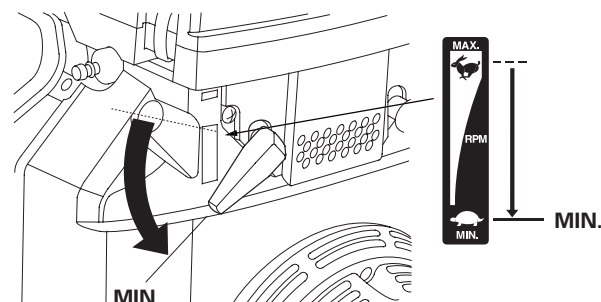

2. Turn the engine switch to the OFF position.

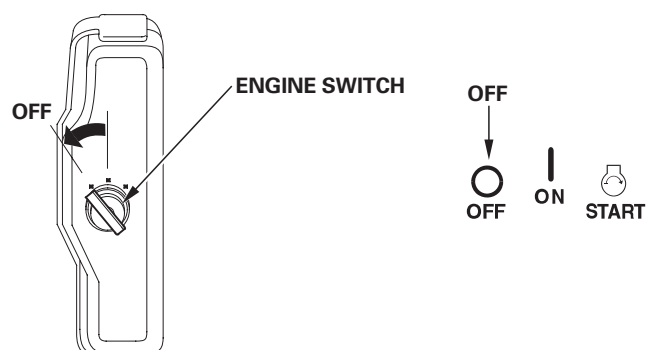

3. If the fuel tank is equipped with a valve, turn the fuel valve to the CLOSED or OFF position.

SETTING ENGINE SPEED

Position the throttle lever for the desired engine speed.

Some engine applications use a remote-mounted throttle control rather than the engine-mounted throttle lever shown here. Refer to the instructions provided by the equipment manufacturer.

For engine speed recommendations, refer to the instructions provided with the equipment powered by this engine.

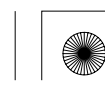
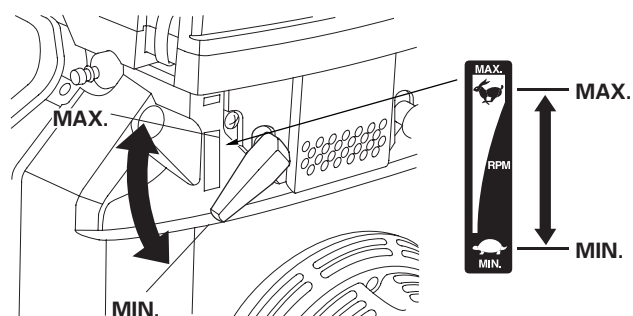



SERVICING YOUR ENGINE

THE IMPORTANCE OF MAINTENANCE

Good maintenance is essential for safe, economical and trouble-free operation. It will also help reduce pollution.

WARNING

Improper maintenance, or failure to correct a problem before operation, can cause a malfunction in which you can be seriously hurt or killed.

Always follow the inspection and maintenance recommendations and schedules in this owner's manual.

To help you properly care for your engine, the following pages include a maintenance schedule, routine inspection procedures, and simple maintenance procedures using basic hand tools. Other service tasks that are more difficult, or require special tools, are best handled by professionals and are normally performed by a Honda technician or other qualified mechanic.

The maintenance schedule applies to normal operating conditions. If you operate your engine under severe conditions, such as sustained high-load or high-temperature operation, or use in unusually wet or dusty conditions, consult your servicing dealer for recommendations applicable to your individual needs and use.

Maintenance, replacement, or repair of the emission control devices and systems may be performed by any engine repair establishment or individual, using parts that are "certified" to EPA standards.

MAINTENANCE SAFETY

Some of the most important safety precautions follow. However, we cannot warn you of every conceivable hazard that can arise in performing maintenance. Only you can decide whether or not you should perform a given task.

WARNING

Failure to properly follow maintenance instructions and precautions can cause you to be seriously hurt or killed.

Always follow the procedures and precautions in this owner's manual.

SAFETY PRECAUTIONS

- Make sure the engine is off before you begin any maintenance or repairs. This will eliminate several potential hazards:
 - **Carbon monoxide poisoning from engine exhaust.**
Be sure there is adequate ventilation whenever you operate the engine.
 - **Burns from hot parts.**
Let the engine and exhaust system cool before touching.
 - **Injury from moving parts.**
Do not run the engine unless instructed to do so.
- Read the instructions before you begin, and make sure you have the tools and skills required.
- To reduce the possibility of fire or explosion, be careful when working around gasoline. Use only a non-flammable solvent, not gasoline, to clean parts. Keep cigarettes, sparks and flames away from all fuel related parts.

Remember that an authorized Honda servicing dealer knows your engine best and is fully equipped to maintain and repair it.

To ensure the best quality and reliability, use only new genuine Honda parts or their equivalents for repair and replacement.

MAINTENANCE SCHEDULE

REGULAR SERVICE PERIOD (3) Perform at every indicated month or operating hour interval, whichever comes first.		Each Use	First Month or 20 Hrs	Every 3 Months or 50 Hrs	Every 6 Months or 100 Hrs	Every Year or 300 Hrs	Refer to Page
ITEM							
Engine oil	Check level	○					7
	Change		○		○		8
Engine oil filter	Replace					Every 200 Hrs	8
Air cleaner	Check	○					9
	Clean			○ (1)			9
	Replace					○ *	10
Spark plug	Check-adjust				○		10
	Replace					○	11
Spark arrester (applicable types)	Clean				○		11
Idle speed	Check-adjust					○ (2)	**
Valve clearance	Check-adjust					○ (2)	**
Combustion chamber	Clean	After every 500 Hrs. (2)					**
Fuel filter	Check				○		10
	Replace					○ (2)	**
Fuel tank	Clean	Every year (2)					**
Fuel tube	Check	Every 2 years (Replace if necessary) (2)					**

* Replace the paper air filter element only.

** Refer to the Shop Manual.

- (1) Service more frequently when used in dusty areas.
- (2) These items should be serviced by your Honda servicing dealer, unless you have the proper tools and are mechanically proficient. Refer to the Honda shop manual for service procedures.
- (3) For commercial use, log hours of operation to determine proper maintenance intervals.

Failure to follow this maintenance schedule could result in non-warrantable failures.





REFUELING

Recommended Fuel

Unleaded gasoline	
U.S.	Pump octane rating 86 or higher
Except U.S.	Research octane rating 91 or higher Pump octane rating 86 or higher

This engine is certified to operate on unleaded gasoline with a pump octane rating of 86 or higher (a research octane rating of 91 or higher).

Refuel in a well-ventilated area with the engine stopped. If the engine has been running, allow it to cool first. Never refuel the engine inside a building where gasoline fumes may reach flames or sparks.

You may use regular unleaded gasoline containing no more than 10% ethanol (E10) or 5% methanol by volume. In addition, methanol must contain cosolvents and corrosion inhibitors. Use of fuels with content of ethanol or methanol greater than shown above may cause starting and/or performance problems. It may also damage metal, rubber, and plastic parts of the fuel system. Engine damage or performance problems that result from using a fuel with percentages of ethanol or methanol greater than shown above are not covered under warranty.

If your equipment will be used on an infrequent or intermittent basis, please refer to the fuel section of the HELPFUL TIPS AND SUGGESTIONS chapter (see page 11) for additional information regarding fuel deterioration.

⚠ WARNING

Gasoline is highly flammable and explosive, and you can be burned or seriously injured when refueling.

- Stop engine and keep heat, sparks, and flame away.
- Refuel only outdoors.
- Wipe up spills immediately.

NOTICE

Fuel can damage paint and some types of plastic. Be careful not to spill fuel when filling your fuel tank. Damage caused by spilled fuel is not covered under the Distributor's Limited Warranty.

Never use stale or contaminated gasoline or oil/gasoline mixture. Avoid getting dirt or water in the fuel tank.

1. With the engine stopped and on a level surface, remove the fuel filler cap and check the fuel level. Refill the tank if the fuel level is low.

Refer to the instructions provided with the equipment powered by this engine for refuelling.

Refuel in a well-ventilated area before starting the engine. If the engine has been running, allow it to cool. Refuel carefully to avoid spilling fuel. It may be necessary to lower the fuel level depending on operating conditions. After refueling, tighten the fuel tank cap securely.

Keep gasoline away from appliance pilot lights, barbecues, electric appliances, power tools, etc.

Spilled fuel is not only a fire hazard, it causes environmental damage. Wipe up spills immediately.

ENGINE OIL

Oil is a major factor affecting performance and service life. Use 4-stroke automotive detergent oil.

Recommended Oil

Use 4-stroke motor oil that meets or exceeds the requirements for API service classification SJ or later (or equivalent). Always check the API service label on the oil container to be sure it includes the letters SJ or later (or equivalent).

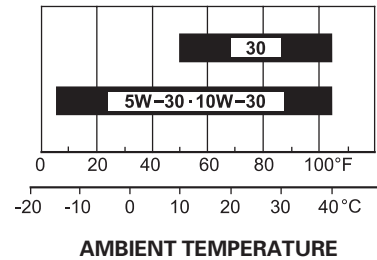

SAE 10W-30 is recommended for general use. Other viscosities shown in the chart may be used when the average temperature in your area is within the indicated range.

Oil Level Check

Check the engine oil level with the engine stopped and in a level position.

1. GX670 ONLY: Start the engine and let it idle for 1 or 2 minutes. Stop the engine and wait for 2 or 3 minutes.
2. Remove the dipstick and wipe it clean.
3. Fully insert the dipstick, then remove it to check the oil level.
4. If the oil level is low, remove the oil filler cap, and fill with the recommended oil to the upper limit mark on the dipstick.
5. Reinstall the dipstick and filler cap.

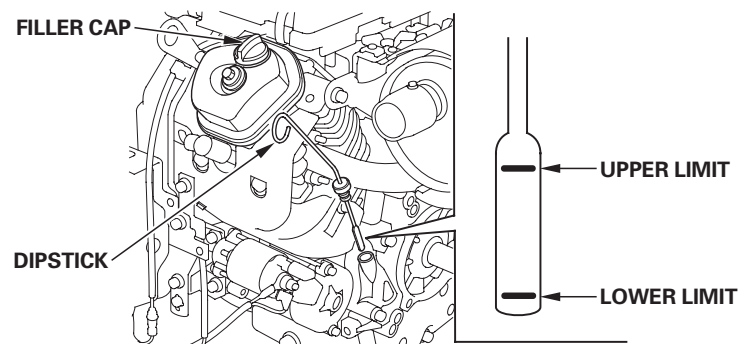

NOTICE

Running the engine with a low oil level can cause engine damage. This type of damage is not covered by the Distributor's Limited Warranty.

The Oil Alert system (applicable types) will automatically stop the engine before the oil level falls below the safe limit. However, to avoid the inconvenience of an unexpected shutdown, always check the engine oil level before startup.





Oil Change

Drain the used oil when the engine is warm. Warm oil drains quickly and completely.

1. Place a suitable container below the engine to catch the used oil, then remove the filler cap, drain bolt and washer.
2. Allow the used oil to drain completely, then reinstall the drain bolt and new washer, and tighten the drain bolt securely.

Please dispose of used motor oil in a manner that is compatible with the environment. We suggest you take used oil in a sealed container to your local recycling center or service station for reclamation. Do not throw it in the trash, pour it on the ground, or pour it down a drain.

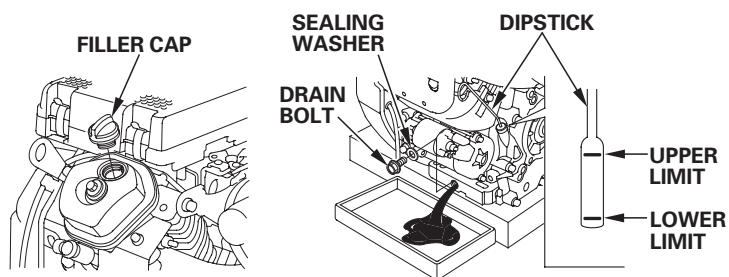

3. With the engine in a level position, fill with the recommended oil to the upper limit mark on the dipstick.

NOTICE

Running the engine with a low oil level can cause engine damage. This type of damage is not covered by the Distributor's Limited Warranty.

The Oil Alert system (applicable types) will automatically stop the engine before the oil level falls below the safe limit. However, to avoid the inconvenience of an unexpected shutdown, fill to the upper limit, and check the oil level regularly.

4. Reinstall the filler cap and dipstick securely.

OIL FILTER

Change

1. Drain the engine oil, and retighten the drain bolt securely.
2. Remove the oil filter, and drain the oil into a suitable container. Dispose the used oil and filter in a manner compatible with the environment.

NOTICE

Use an oil filter socket, rather than a strap wrench, to avoid striking and damaging the oil pressure switch.

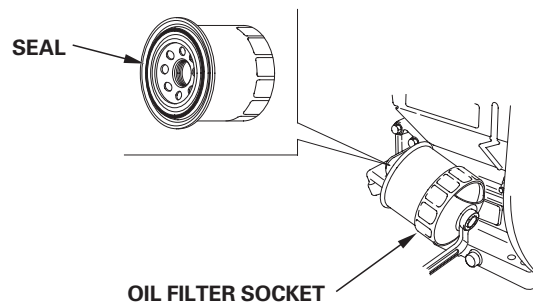

3. Clean the filter mounting base, and coat the seal of the new oil filter with clean engine oil.

NOTICE

Use only a genuine Honda oil filter or a filter of equivalent quality specified for your model. Using the wrong filter, or a non-Honda filter which is not of equivalent quality, may cause engine damage.

4. Screw on the new oil filter by hand until the seal contacts the filter mounting base, then use an oil filter socket tool to tighten the filter an additional 7/8 turn.

Oil filter tightening torque: 22 N·m (2.2 kgf·m , 16 lbf·ft)

5. Refill the crankcase with the specified amount of the recommended oil (see page 7). Reinstall the oil filler cap and dipstick.
6. Start the engine, and check for leaks.
7. Stop the engine, and check the oil level as described on page 7 . If necessary, add oil to bring the oil level to the upper limit mark on the dipstick.





AIR CLEANER

A dirty air cleaner will restrict air flow to the carburetor, reducing engine performance. If you operate the engine in very dusty areas, clean the air filter more often than specified in the MAINTENANCE SCHEDULE.

NOTICE

Operating the engine without an air filter, or with a damaged air filter, will allow dirt to enter the engine, causing rapid engine wear. This type of damage is not covered by the Distributor's Limited Warranty.

Inspection

Remove the air cleaner cover and inspect the filter elements. Clean or replace dirty filter elements. Always replace damaged filter elements.

Cleaning

Standard Type:

1. Release four latch tabs from the air cleaner cover, and remove the cover.
2. Remove the foam filter from the cover.
3. Remove the paper filter from the air cleaner case.

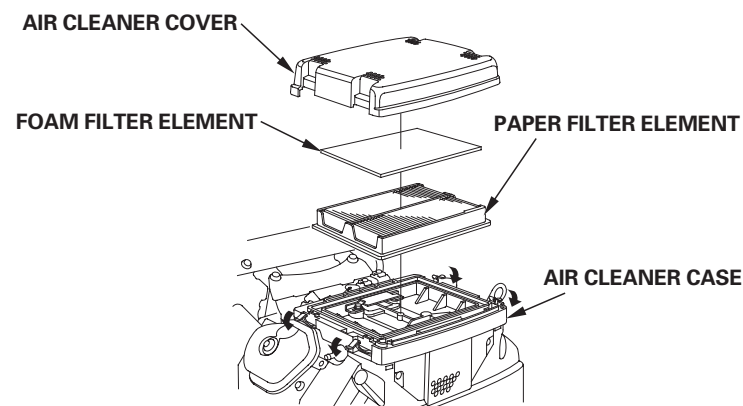

4. Inspect both air filter elements, and replace them if they are damaged. Always replace the paper air filter element at the scheduled interval (see page 6).

5. Clean the air filter elements if they are to be reused.

Paper air filter element: Tap the filter element several times on a hard surface to remove dirt, or blow compressed air [not exceeding 207 kPa (2.1 kgf/cm², 30 psi)] through the filter element from the air cleaner case side.

Never try to brush off dirt; brushing will force dirt into the fibers. Replace the paper element if it is excessively dirty.

Foam air filter element: Clean in warm soapy water, rinse, and allow to dry thoroughly. Or clean in non-flammable solvent and allow to dry. Do not put oil on the foam element.

6. Wipe dirt from the inside of the air cleaner body and cover, using a moist rag. Be careful to prevent dirt from entering the air chamber that leads to the carburetor.

7. Place the foam air filter element in the air cleaner cover, then reinstall the paper air filter element and cover to the air cleaner case. Hook the four latch tabs securely.

Snorkel Type:

1. Remove the wing nut from the air cleaner cover, and remove the cover.
2. Remove the wing nut from the paper filter element.
3. Remove the paper filter element from the air cleaner case.

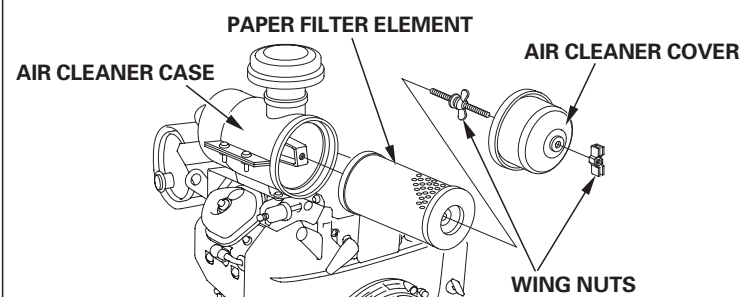

4. Inspect the paper air filter element, and replace it if it is damaged. Always replace the paper air filter element at the scheduled interval (see page 6).

5. Clean the paper air filter element if it is to be reused.

Tap the filter element several times on a hard surface to remove dirt, or blow compressed air [not exceeding 207 kPa (2.1 kg/cm², 30 psi)] through the filter element from the inside. Never try to brush off dirt; brushing will force dirt into the fibers.

6. Wipe dirt from the inside of the air cleaner case and cover, using a moist rag. Be careful to prevent dirt from entering the air duct that leads to the carburetor.

7. Reinstall the paper air filter element. Tighten the air filter wing nut securely.

8. Reinstall the air cleaner cover, and tighten the cover wing nut securely.



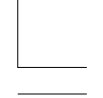

FUEL FILTER

Inspection

1. Check the fuel filter for water accumulation or sediment.

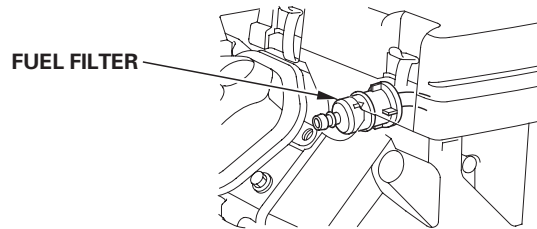

2. If the fuel filter is found with excessive water accumulation or sediment, take the engine to your authorized Honda servicing dealer.

SPARK PLUG

Recommended Spark Plugs: ZGR5A (NGK)
J16CR-U (DENSO)

The recommended spark plugs have the correct heat range for normal engine operating temperatures.

NOTICE

Incorrect spark plugs can cause engine damage.

For good performance, the spark plugs must be properly gapped and free of deposits.

1. Disconnect the spark plug caps, and remove any dirt from around the spark plug area.
2. Remove the spark plugs with a 13/16-inch spark plug wrench.

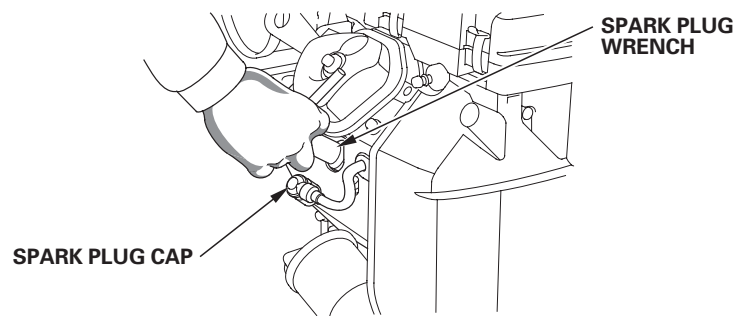

3. Inspect the spark plugs. Replace them if damaged, badly fouled, if the sealing washer is in poor condition, or if the electrode is worn.

4. Measure the spark plug electrode gaps with a wire-type feeler gauge. Correct the gap, if necessary, by carefully bending the side electrode.
The gap should be:
0.7–0.8 mm (0.028–0.031 in)

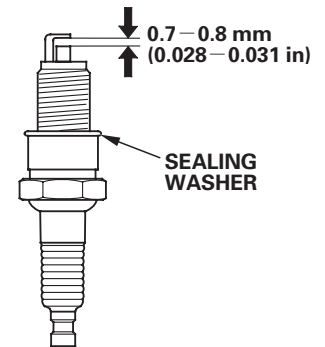

5. Install the spark plug carefully, by hand, to avoid cross-threading.

6. After the spark plug is seated, tighten with a 13/16-inch spark plug wrench to compress the sealing washer.

When installing a new spark plug, tighten 1/2 turn after the spark plug seats to compress the washer.

When reinstalling the original spark plug, tighten 1/8–1/4 turn after the spark plug seats to compress the washer.

NOTICE

A loose spark plug can overheat and damage the engine. Overtightening the spark plug can damage the threads in the cylinder head.

7. Attach the spark plug caps to the spark plugs.

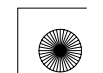

**SPARK ARRESTER (applicable types)**

Your engine is not factory-equipped with a spark arrester. The spark arrester is optional part. In some areas, it is illegal to operate an engine without a spark arrester. Check local laws and regulations. A spark arrester is available from authorized Honda servicing dealers.

The spark arrester must be serviced every 100 hours to keep it functioning as designed.

If the engine has been running, the muffler will be hot. Allow it to cool before servicing the spark arrester.

Spark Arrester Cleaning & Inspection

1. Remove the spark arrester:

HIGH-MOUNT MUFFLER TYPE: Remove the special screw from the muffler and remove the spark arrester.

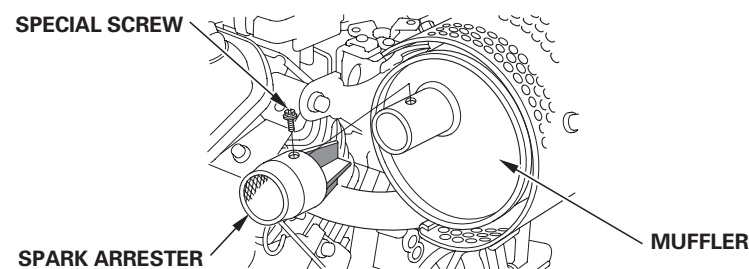

SIDE-MOUNT MUFFLER TYPE: Remove the 6 mm flange bolts from the muffler protector and remove the muffler protector. Remove the special screws from the spark arrester and remove the spark arrester from the muffler.

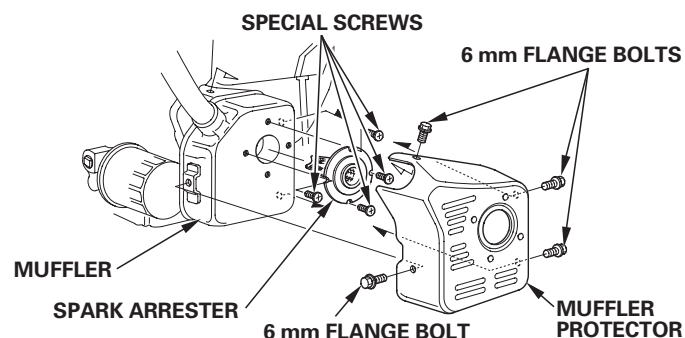

2. Use a brush to remove carbon deposits from the spark arrester screen. Be careful to avoid damaging the screen.

The spark arrester must be free of breaks and holes. Replace the spark arrester if it is damaged.

HIGH-MOUNT MUFFLER TYPE **SIDE-MOUNT MUFFLER TYPE**

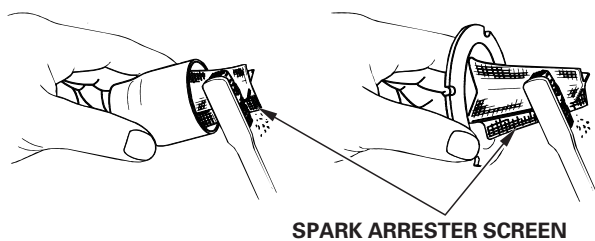

3. Install the spark arrester and muffler protector in the reverse order of disassembly.

HELPFUL TIPS & SUGGESTIONS**STORING YOUR ENGINE****Storage Preparation**

Proper storage preparation is essential for keeping your engine trouble-free and looking good. The following steps will help to keep rust and corrosion from impairing your engine's function and appearance, and will make the engine easier to start when you use it again.

Cleaning

If the engine has been running, allow it to cool for at least half an hour before cleaning. Clean all exterior surfaces, touch up any damaged paint, and coat other areas that may rust with a light film of oil.

NOTICE

Using a garden hose or pressure washing equipment can force water into the air cleaner or muffler opening. Water in the air cleaner will soak the air filter, and water that passes through the air filter or muffler can enter the cylinder, causing damage.

Fuel**NOTICE**

Depending on the region where you operate your equipment, fuel formulations may deteriorate and oxidize rapidly. Fuel deterioration can occur in as little as 30 days and may cause damage to the carburetor and/or fuel system. Please check with your servicing dealer for local storage recommendations.

Gasoline will oxidize and deteriorate in storage. Deteriorated gasoline will cause hard starting, and it leaves gum deposits that clog the fuel system. If the gasoline in your engine deteriorates during storage, you may need to have the carburetor and other fuel system components serviced or replaced.

The length of time that gasoline can be left in your fuel tank and carburetor without causing functional problems will vary with such factors as gasoline blend, your storage temperatures, and whether the fuel tank is partially or completely filled. The air in a partially filled fuel tank promotes fuel deterioration. Very warm storage temperatures accelerate fuel deterioration. Fuel deterioration problems may occur within a few months, or even less if the gasoline was not fresh when you filled the fuel tank.

Fuel system damage or engine performance problems resulting from neglected storage preparation are not covered under the *Distributor's Limited Warranty*.

You can extend fuel storage life by adding a gasoline stabilizer that is formulated for that purpose, or you can avoid fuel deterioration problems by draining the fuel tank and carburetor.

Adding a Gasoline Stabilizer to Extend Fuel Storage Life

When adding a gasoline stabilizer, fill the fuel tank with fresh gasoline. If only partially filled, air in the tank will promote fuel deterioration during storage. If you keep a container of gasoline for refueling, be sure that it contains only fresh gasoline.

1. Add gasoline stabilizer following the manufacturer's instructions.
2. After adding a gasoline stabilizer, run the engine outdoors for 10 minutes to be sure that treated gasoline has replaced the untreated gasoline in the carburetor.
3. Stop the engine, and if the fuel tank is equipped with a fuel valve, move the fuel valve to the CLOSED or OFF position.





Draining the Fuel Tank and Carburetor

⚠ WARNING

Gasoline is highly flammable and explosive, and you can be burned or seriously injured when handling fuel.

- Stop engine and keep heat, sparks, and flame away.
- Refuel only outdoors.
- Wipe up spills immediately.

1. Disconnect the fuel line to the engine, and drain the fuel tank into an approved gasoline container. If the fuel tank is equipped with a valve, turn the fuel valve to the OPEN or ON position to enable draining. After draining is completed, reconnect the fuel line.
2. Loosen the carburetor drain screw, and drain the carburetor into an approved gasoline container. After draining is completed, tighten the carburetor drain screw.

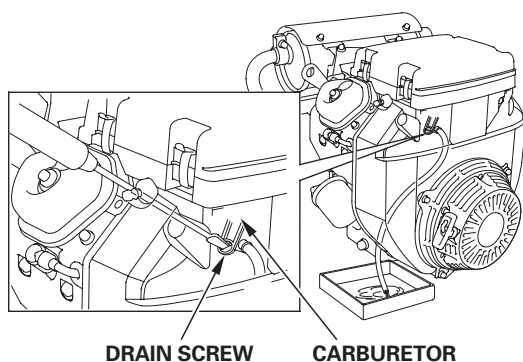

DRAIN SCREW CARBURETOR

Engine Oil

1. Change the engine oil (see page 8).
2. Remove the spark plugs (see page 10).
3. Pour a tablespoon 5 – 10 cm³ (5 – 10 cc) of clean engine oil into each cylinder.
4. Turn the engine for a few seconds by turning the engine switch to the START position to distribute the oil in the cylinders.
5. Reinstall the spark plugs.

Storage Precautions

If your engine will be stored with gasoline in the fuel tank and carburetor, it is important to reduce the hazard of gasoline vapor ignition. Select a well-ventilated storage area away from any appliance that operates with a flame, such as a furnace, water heater, or clothes dryer. Also avoid any area with a spark-producing electric motor, or where power tools are operated.

If possible, avoid storage areas with high humidity, because that promotes rust and corrosion.

Keep the engine level in storage. Tilting can cause fuel or oil leakage.

Unless all fuel has been drained from the fuel tank, leave the fuel valve in the CLOSED or OFF position to reduce the possibility of fuel leakage.

With the engine and exhaust system cool, cover the engine to keep out dust. A hot engine and exhaust system can ignite or melt some materials. Do not use sheet plastic as a dust cover. A nonporous cover will trap moisture around the engine, promoting rust and corrosion.

If installed, remove the battery and store it in a cool, dry place. Recharge the battery once a month while the engine is in storage. This will help to extend the service life of the battery.

Removal from Storage

Check your engine as described in the *BEFORE OPERATION CHECKS* section of this manual (see page 3).

If the fuel was drained during storage preparation, fill the tank with fresh gasoline. If you keep a container of gasoline for refueling, be sure it contains only fresh gasoline. Gasoline oxidizes and deteriorates over time, causing hard starting.

If the cylinders were coated with oil during storage preparation, the engine may smoke briefly at startup. This is normal.

TRANSPORTING

If the engine has been running, allow it to cool for at least 15 minutes before loading the engine-powered equipment on the transport vehicle. A hot engine and exhaust system can burn you and can ignite some materials.

Keep the engine level when transporting to reduce the possibility of fuel leakage. If the fuel tank is equipped with a fuel valve, move the fuel valve lever to OFF.



**TAKING CARE OF UNEXPECTED PROBLEMS**

ENGINE WILL NOT START	Possible Cause	Correction
1. Electric starting: Check battery and fuse.	Battery discharged.	Recharge battery.
	Fuse burnt out.	Replace fuse.
2. Check control positions.	Fuel valve CLOSED or OFF. (If equipped)	Move lever to OPEN or ON position.
	Choke OPEN.	Move lever to CLOSED position unless the engine is warm.
	Engine switch OFF.	Turn engine switch to ON position.
3. Check engine oil level.	Engine oil level low (Oil Alert stops engine).	Fill with the recommended oil to the proper level (p. 7).
4. Check fuel.	Out of fuel.	Refuel (p. 7).
	Bad fuel; engine stored without treating or draining gasoline, or refueled with bad gasoline.	Drain fuel tank and carburetor (p. 12). Refuel with fresh gasoline (p. 7).
5. Remove and inspect spark plugs.	Spark plugs faulty, fouled, or improperly gapped.	Gap, or replace spark plugs (p. 10).
	Spark plugs wet with fuel (flooded engine).	Dry and reinstall spark plugs. Start engine with throttle lever in FAST position.
6. Take engine to an authorized Honda servicing dealer, or refer to shop manual.	Fuel filter restricted, carburetor malfunction, ignition malfunction, valves stuck, etc.	Replace or repair faulty components as necessary.

ENGINE LACKS POWER	Possible Cause	Correction
1. Check air filter.	Filter element(s) restricted.	Clean or replace filter element(s) (p. 9).
2. Check fuel.	Bad fuel; engine stored without treating or draining gasoline, or refueled with bad gasoline.	Drain fuel tank and carburetor (p. 12). Refuel with fresh gasoline (p. 7).
3. Take engine to an authorized Honda servicing dealer, or refer to shop manual.	Fuel filter restricted, carburetor malfunction, ignition malfunction, valves stuck, etc.	Replace or repair faulty components as necessary.

FUSE REPLACEMENT

The electric starter relay circuit and battery charging circuit are protected by a 25-ampere fuse. If the fuse burns out, the electric starter will not operate. The engine can be started manually if the fuse burns out, but running the engine will not charge the battery.

1. Remove the 6 × 12 mm screw from the rear cover of the engine switch box.
2. Remove the fuse cover, and inspect the fuse.

If the fuse is burnt out, remove the fuse cover, then pull out and discard the burnt-out fuse. Install a new 25-ampere fuse, and reinstall the fuse cover.

NOTICE

Never use a fuse with a rating greater than 25 amperes. Serious damage to the electrical system or a fire could result.

3. Reinstall the rear cover. Install the 6 × 12 mm screw and tighten it securely.

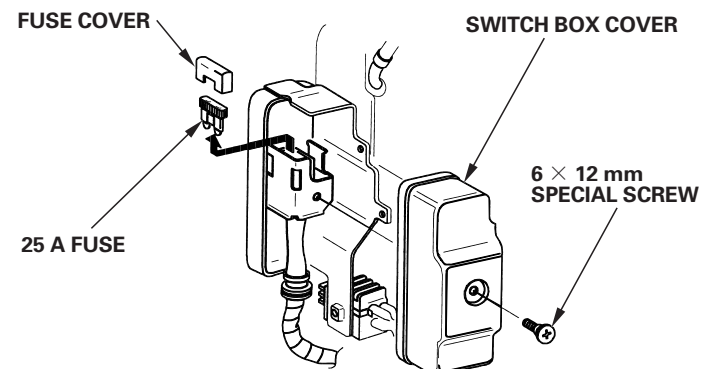

Frequent fuse failure usually indicates a short circuit or an overload in the electrical system. If the fuse burns out frequently, take the engine to a servicing Honda dealer for repair.





TECHNICAL INFORMATION

Serial Number Location

Record the engine serial number, type and purchase date in the space below. You will need this information when ordering parts and when making technical or warranty inquiries.

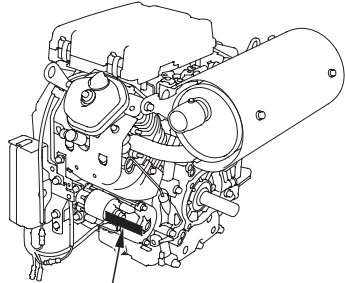

**SERIAL NUMBER &
ENGINE TYPE LOCATION**

Engine serial number: _____

Engine type: _____

Date Purchased: ____ / ____ / ____

Battery Connections for Electric Starter

Recommended Battery

GX610	12 V – 45 Ah
GX620	
GX670	

Be careful not to connect the battery in reverse polarity, as this will short circuit the battery charging system. Always connect the positive (+) battery cable to the battery terminal before connecting the negative (-) battery cable, so your tools cannot cause a short circuit if they touch a grounded part while tightening the positive (+) battery cable end.

⚠ WARNING

A battery can explode if you do not follow the correct procedure, seriously injuring anyone nearby.

Keep all sparks, open flames, and smoking materials away from the battery.

WARNING: Battery posts, terminals, and related accessories contain lead and lead compounds. Wash hands after handling.

1. Connect the battery positive (+) cable to the starter solenoid terminal as shown.
2. Connect the battery negative (-) cable to an engine mounting bolt, frame bolt, or other good engine ground connection.
3. Connect the battery positive (+) cable to the battery positive (+) terminal as shown.
4. Connect the battery negative (-) cable to the battery negative (-) terminal as shown.
5. Coat the terminals and cable ends with grease.

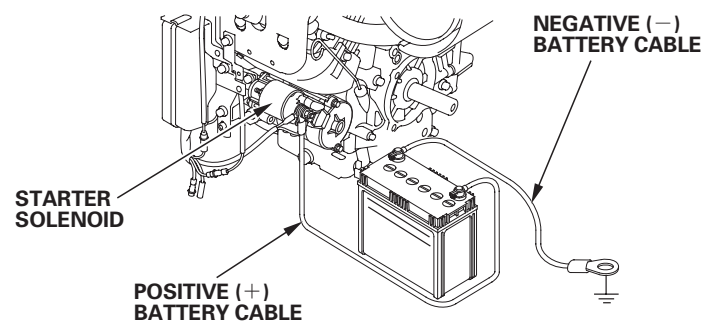



Remote Control Linkage

The throttle and choke control levers are provided with holes for optional cable attachment. The following illustrations show installation examples for a solid wire cable and for a flexible, braided wire cable.

REMOTE THROTTLE AND REMOTE CHOKE

BRAIDED WIRE CABLE TYPE

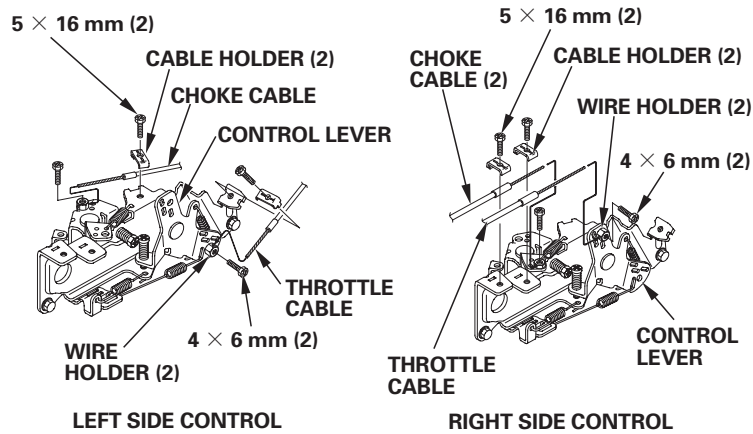

SOLID WIRE CABLE TYPE

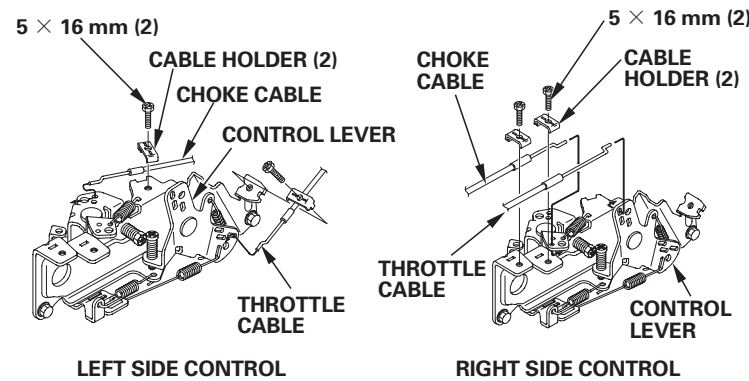

REMOTE THROTTLE AND MANUAL CHOKE

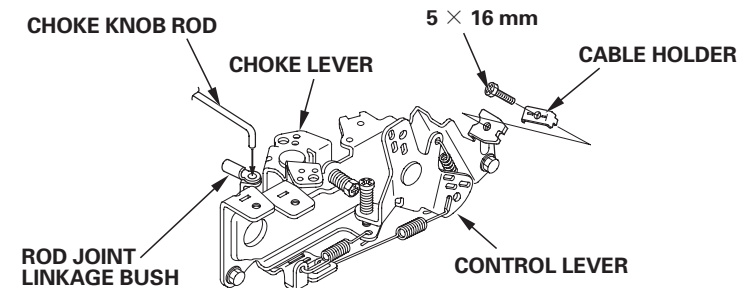

MANUAL THROTTLE AND MANUAL CHOKE

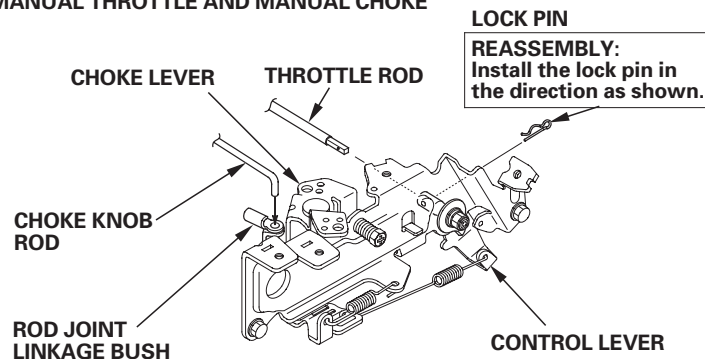

Carburetor Modifications for High Altitude Operation

At high altitude, the standard carburetor air-fuel mixture will be too rich. Performance will decrease, and fuel consumption will increase. A very rich mixture will also foul the spark plug and cause hard starting. Operation at an altitude that differs from that at which this engine was certified, for extended periods of time, may increase emissions.

High altitude performance can be improved by specific modifications to the carburetor. If you always operate your engine at altitudes above 1,500 meters (5,000 feet), have your servicing dealer perform this carburetor modification. This engine, when operated at high altitude with the carburetor modifications for high altitude use, will meet each emission standard throughout its useful life.

Even with carburetor modification, engine horsepower will decrease about 3.5% for each 300-meter (1,000-foot) increase in altitude. The effect of altitude on horsepower will be greater than this if no carburetor modification is made.

NOTICE

When the carburetor has been modified for high altitude operation, the air-fuel mixture will be too lean for low altitude use. Operation at altitudes below 1,500 meters (5,000 feet) with a modified carburetor may cause the engine to overheat and result in serious engine damage. For use at low altitudes, have your servicing dealer return the carburetor to original factory specifications.





Emission Control System Information

Source of Emissions

The combustion process produces carbon monoxide, oxides of nitrogen, and hydrocarbons. Control of hydrocarbons and oxides of nitrogen is very important because, under certain conditions, they react to form photochemical smog when subjected to sunlight. Carbon monoxide does not react in the same way, but it is toxic.

Honda utilizes appropriate air/fuel ratios and other emissions control systems to reduce the emissions of carbon monoxide, oxides of nitrogen and hydrocarbons. Additionally, Honda fuel systems utilize components and control technologies to reduce evaporative emissions.

The U.S., California Clean Air Acts and Environment Canada

EPA, California and Canadian regulations require all manufacturers to furnish written instructions describing the operation and maintenance of emission control systems.

The following instructions and procedures must be followed in order to keep the emissions from your Honda engine within the emission standards.

Tampering and Altering

Tampering with or altering the emission control system may increase emissions beyond the legal limit. Among those acts that constitute tampering are:

- Removal or alteration of any part of the intake, fuel, or exhaust systems.
- Altering or defeating the governor linkage or speed-adjusting mechanism to cause the engine to operate outside its design parameters.

Problems That May Affect Emissions

If you are aware of any of the following symptoms, have your engine inspected and repaired by your servicing dealer.

- Hard starting or stalling after starting.
- Rough idle.
- Misfiring or backfiring under load.
- Afterburning (backfiring).
- Black exhaust smoke or high fuel consumption.

Replacement Parts

The emission control systems on your Honda engine were designed, built, and certified to conform with EPA, California (models certified for sale in California), and Canadian emission regulations. We recommend the use of genuine Honda parts whenever you have maintenance done. These original-design replacement parts are manufactured to the same standards as the original parts, so you can be confident of their performance. The use of replacement parts that are not of the original design and quality may impair the effectiveness of your emission control system.

A manufacturer of an aftermarket part assumes the responsibility that the part will not adversely affect emission performance. The manufacturer or rebuilder of the part must certify that use of the part will not result in a failure of the engine to comply with emission regulations.

Maintenance

Follow the maintenance schedule on page 6. Remember that this schedule is based on the assumption that your machine will be used for its designed purpose. Sustained high-load or high-temperature operation, or use in unusually wet or dusty conditions, will require more frequent service.

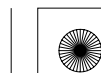

**Air Index**

(Models certified for sale in California)

An Air Index Information label is applied to engines certified to an emission durability time period in accordance with the requirements of the California Air Resources Board.

The bar graph is intended to provide you, our customer, the ability to compare the emissions performance of available engines. The lower the Air Index, the less pollution.

The durability description is intended to provide you with information relating to the engine's emission durability period. The descriptive term indicates the useful life period for the engine's emission control system. See your *Emission Control System Warranty* for additional information.

Descriptive Term	Applicable to Emissions Durability Period
Moderate	50 hours [0–80 cm ³ (0–80 cc) inclusive] 125 hours [greater than 80 cm ³ (80 cc)]
Intermediate	125 hours [0–80 cm ³ (0–80 cc) inclusive] 250 hours [greater than 80 cm ³ (80 cc)]
Extended	300 hours [0–80 cm ³ (0–80 cc) inclusive] 500 hours [greater than 80 cm ³ (80 cc)] 1,000 hours [225 cm ³ (225 cc) and greater]

Specifications**GX610 (QAF-Type)**

Length × Width × Height	388 × 457 × 452 mm (15.3 × 18.0 × 17.8 in)
Dry mass [weight]	42.1 kg (92.8 lbs)
Engine type	4-stroke, overhead valve, 2 cylinders (90° V-Twin)
Displacement [Bore × Stroke]	614 cm ³ (37.5 cu-in) [77.0 × 66.0 mm (3.03 × 2.60 in)]
Net power <small>(in accordance with SAE J1349*)</small>	12.4 kW (16.9 PS, 16.6 bhp) at 3,600 rpm
Max. Net torque <small>(in accordance with SAE J1349*)</small>	39.6 N·m (4.04 kgf·m, 29.2 lbf·ft) at 2,500 rpm
Engine oil capacity	Without oil filter replacement: approximately 1.1 ℓ (1.2 US qt, 1.0 Imp qt) With oil filter replacement: approximately 1.4 ℓ (1.5 US qt, 1.2 Imp qt)
Cooling system	Forced air
Ignition system	Transistor magneto
PTO shaft rotation	Counterclockwise

GX620 (QAF-Type)

Length × Width × Height	388 × 457 × 452 mm (15.3 × 18.0 × 17.8 in)
Dry mass [weight]	42.1 kg (92.8 lbs)
Engine type	4-stroke, overhead valve, 2 cylinders (90° V-Twin)
Displacement [Bore × Stroke]	614 cm ³ (37.5 cu-in) [77.0 × 66.0 mm (3.03 × 2.60 in)]
Net power <small>(in accordance with SAE J1349*)</small>	13.5 kW (18.4 PS, 18.1 bhp) at 3,600 rpm
Max. Net torque <small>(in accordance with SAE J1349*)</small>	40.6 N·m (4.14 kgf·m, 29.9 lbf·ft) at 2,500 rpm
Engine oil capacity	Without oil filter replacement: approximately 1.1 ℓ (1.2 US qt, 1.0 Imp qt) With oil filter replacement: approximately 1.4 ℓ (1.5 US qt, 1.2 Imp qt)
Cooling system	Forced air
Ignition system	Transistor magneto
PTO shaft rotation	Counterclockwise

GX670 (TAF-Type)

Length × Width × Height	412 × 471 × 457 mm (16.2 × 18.5 × 18.0 in)
Dry mass [weight]	43.5 kg (95.9 lbs)
Engine type	4-stroke, overhead valve, 2 cylinders (90° V-Twin)
Displacement [Bore × Stroke]	670 cm ³ (40.9 cu-in) [77.0 × 72.0 mm (3.03 × 2.83 in)]
Net power <small>(in accordance with SAE J1349*)</small>	15.3 kW (20.8 PS, 20.5 bhp) at 3,600 rpm
Max. Net torque <small>(in accordance with SAE J1349*)</small>	46.0 N·m (4.69 kgf·m, 33.9 lbf·ft) at 2,500 rpm
Engine oil capacity	Without oil filter replacement: approximately 1.1 ℓ (1.2 US qt, 1.0 Imp qt) With oil filter replacement: approximately 1.4 ℓ (1.5 US qt, 1.2 Imp qt)
Cooling system	Forced air
Ignition system	Transistor magneto
PTO shaft rotation	Counterclockwise

* The power rating of the engine indicated in this document is the net power output tested on a production engine for the engine model and measured in accordance with SAE J1349 at 3,600 rpm (Net Power) and at 2,500 rpm (Max. Net Torque). Mass production engines may vary from this value. Actual power output for the engine installed in the final machine will vary depending on numerous factors, including the operating speed of the engine in application, environmental conditions, maintenance, and other variables.





Tuneup Specifications GX610/620/670

ITEM	SPECIFICATION	MAINTENANCE
Spark plug gap	0.7–0.8 mm (0.028–0.031 in)	Refer to page 10
Idle speed	1,400 ± 150 rpm	See your authorized Honda dealer
Valve clearance (cold)	IN: 0.15 ± 0.02 mm EX: 0.20 ± 0.02 mm	See your authorized Honda dealer
Other specifications	No other adjustments needed.	

Quick Reference Information

Fuel	Unleaded gasoline (Refer to page 7).	
	U. S.	Pump octane rating 86 or higher
	Except U. S.	Research octane rating 91 or higher Pump octane rating 86 or higher
Engine oil	SAE 10W-30, API SJ or later, for general use. Refer to page 7.	
Spark plug	ZGR5A (NGK) J16CR-U (DENSO)	
Maintenance	Before each use:	
	<ul style="list-style-type: none"> • Check engine oil level. Refer to page 7. • Check air filter. Refer to page 9. 	
	First 20 hours:	
	<ul style="list-style-type: none"> • Change engine oil. Refer to page 8. 	
	Subsequent: Refer to the maintenance schedule on page 6.	

Wiring Diagrams

3 A Charge Coil and Switch Box Type

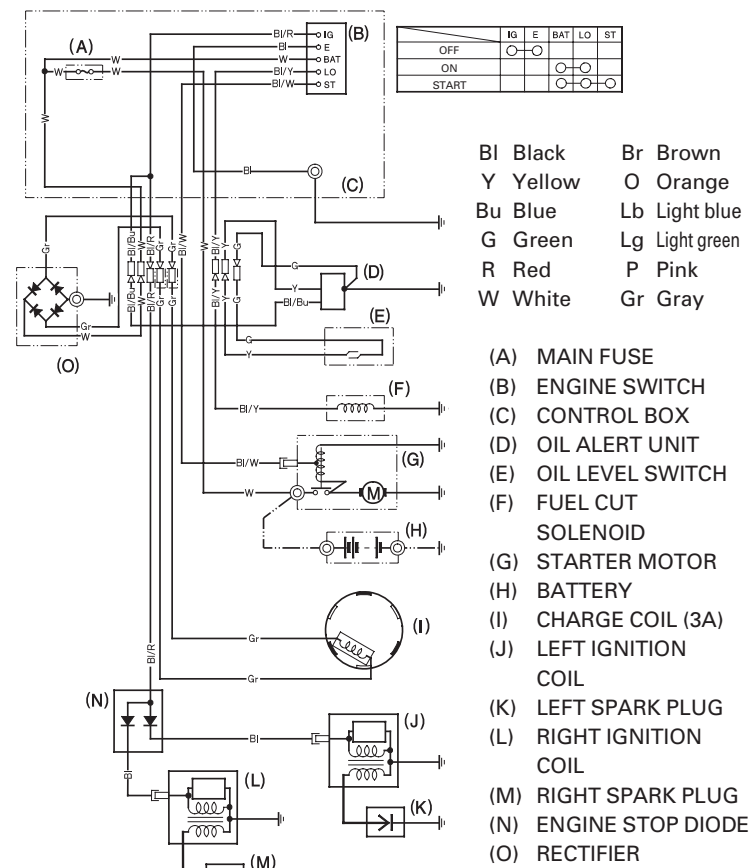

20 A Charge Coil and Switch Box Type

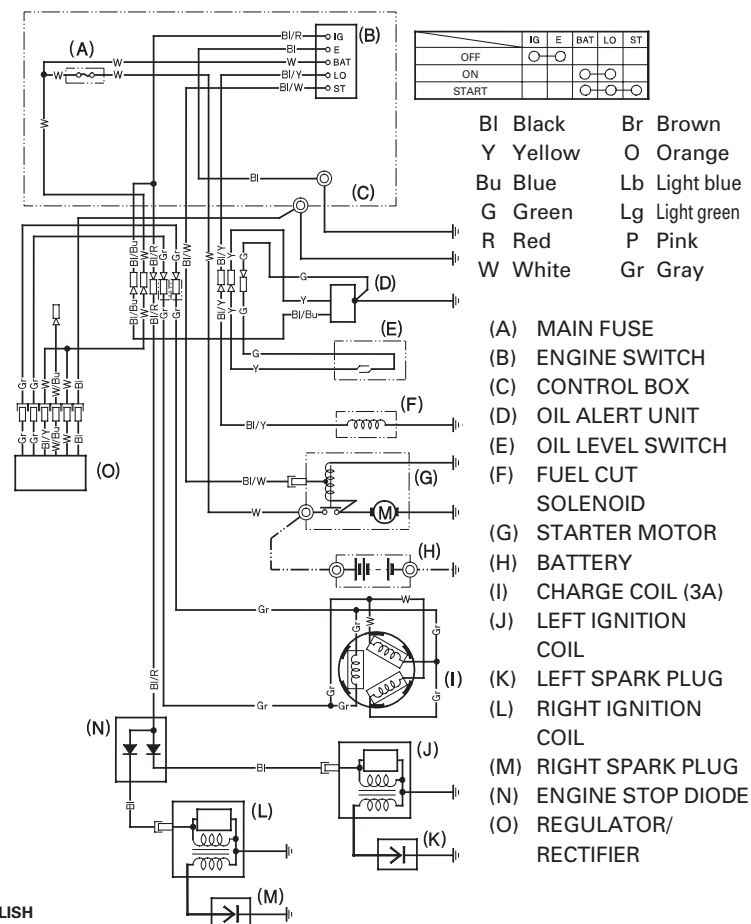

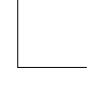

CONSUMER INFORMATION

DISTRIBUTOR/DEALER LOCATOR INFORMATION

United States, Puerto Rico, and U.S. Virgin Islands:

Call (800) 426-7701

or visit our website: www.honda-engines.com

Canada:

Call (888) 9HONDA9

or visit our website: www.honda.ca

For European Area:

visit our website: <http://www.honda-engines-eu.com>

CUSTOMER SERVICE INFORMATION

Servicing dealership personnel are trained professionals. They should be able to answer any question you may have. If you encounter a problem that your dealer does not solve to your satisfaction, please discuss it with the dealership's management. The Service Manager, General Manager, or Owner can help. Almost all problems are solved in this way.

United States, Puerto Rico, and U.S. Virgin Islands:

If you are dissatisfied with the decision made by the dealership's management, contact the Honda Regional Engine Distributor for your area.

If you are still dissatisfied after speaking with the Regional Engine Distributor, you may contact the Honda Office as shown.

All Other Areas:

If you are dissatisfied with the decision made by the dealership's management, contact the Honda Office as shown.

«Honda's Office»

When you write or call, please provide this information:

- Equipment manufacturer's name and model number that the engine is mounted on
- Engine model, serial number, and type (see page 14)
- Name of dealer who sold the engine to you
- Name, address, and contact person of the dealer who services your engine
- Date of purchase
- Your name, address and telephone number
- A detailed description of the problem

United States, Puerto Rico, and U.S. Virgin Islands:

American Honda Motor Co., Inc.

Power Equipment Division

Customer Relations Office

4900 Marconi Drive

Alpharetta, GA 30005-8847

Or telephone: (770) 497-6400, 8:30 am - 8:00 pm EST

Canada:

Honda Canada, Inc.

715 Milner Avenue

Toronto, ON

M1B 2K8

Telephone: (888) 9HONDA9 Toll free

(888) 946-6329

English: (416) 299-3400

Local Toronto dialing area

French: (416) 287-4776

Local Toronto dialing area

Facsimile: (877) 939-0909 Toll free

(416) 287-4776

Local Toronto dialing area

Australia:

Honda Australia Motorcycle and Power Equipment Pty. Ltd.

1954 – 1956 Hume Highway Campbellfield Victoria 3061

Telephone: (03) 9270 1111

Facsimile: (03) 9270 1133

For European Area:

Honda Europe NV.

European Engine Center

<http://www.honda-engines-eu.com>

All Other Areas:

Please contact the Honda distributor in your area for assistance.



HONDA

The Power of Dreams





05/03/22 19:41:01 32Z6C600_020

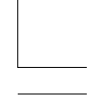

HONDA
The Power of Dreams

