



TSURUMI PUMP

**LH-W SERIES
HIGH HEAD - DEWATERING PUMPS**

DIMENSIONS

**LH322W-61
LH430W-61**

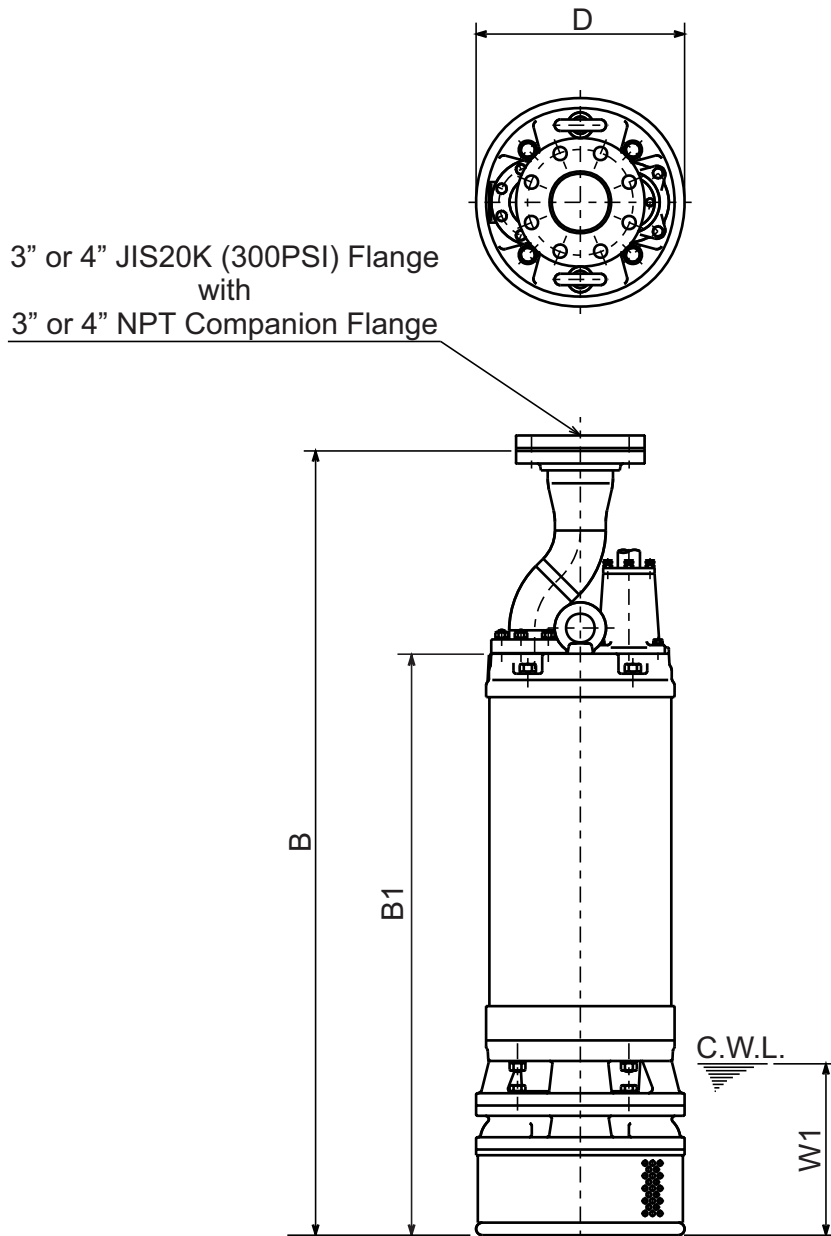

DIMENSIONS:USCS (Inch)

C.W.L. : Continuous running Water Level

Model	HP	NOM. SIZE	Pump & Motor			C.W.L.	Wt. (lbs.)
			B	B1	D	W1	
LH322W-61	30	3"	48 5/8	38 1/2	13	11 3/4	670
LH430W-61	40	4"	54 1/8	40 1/16	14 3/8	11 3/4	715

DIMENSIONS:METRIC (mm)

Model	HP	NOM. SIZE	Pump & Motor			C.W.L.	Wt. (kg)
			B	B1	D	W1	
LH322W-61	22	80	1235	978	330	300	304
LH430W-61	30	100	1375	1018	365	300	324