

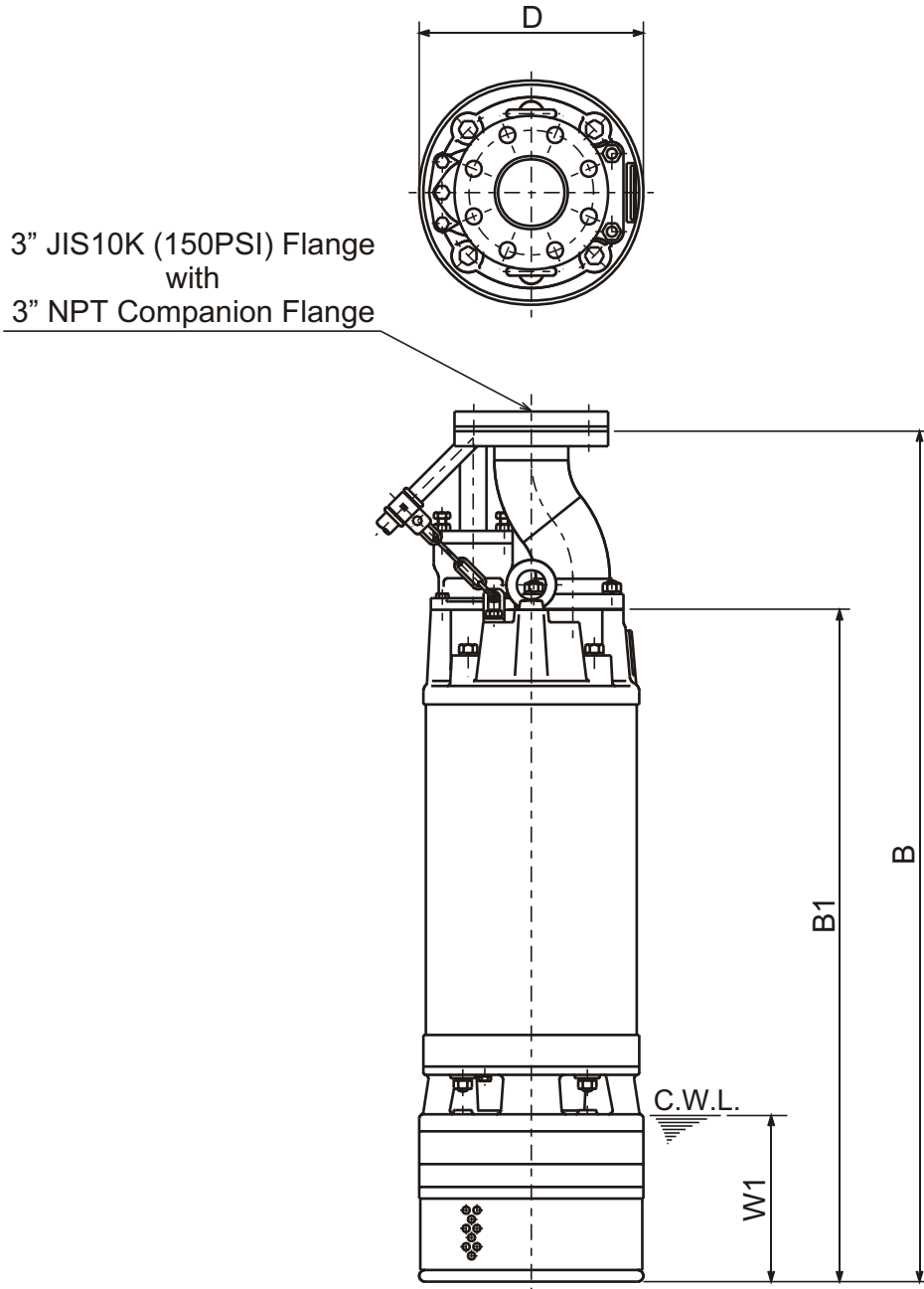

LH-W SERIES
HIGH HEAD - DEWATERING PUMPS

DIMENSIONS

LH311W-60



C.W.L. : Continuous running Water Level

DIMENSIONS:USCS (Inch)

Model	HP	NOM. SIZE	Pump & Motor			C.W.L.	*Wt. (lbs.)
			B	B1	D	W1	
LH311W-60	15	3"	40 5/16	31 7/8	10 5/8	7 7/8	287

DIMENSIONS:METRIC (mm)

*Excluding Cable

Model	HP	NOM. SIZE	Pump & Motor			C.W.L.	*Wt. (kg)
			B	B1	D	W1	
LH311W-60	11	80	1024	809	270	200	130