

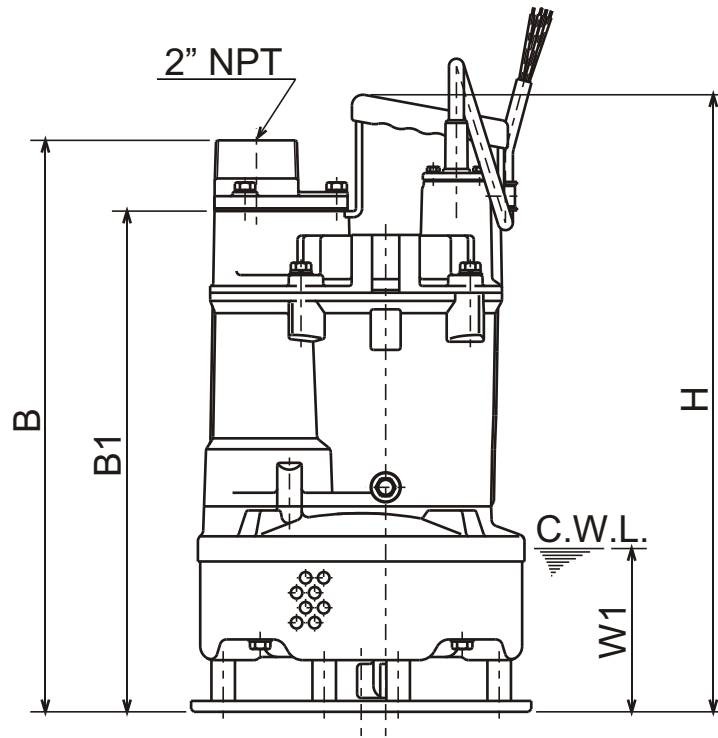

**KTV - SERIES (SAND)  
SEMI-VORTEX - AGITATOR PUMPS**

**DIMENSIONS**

**KTV2-50**

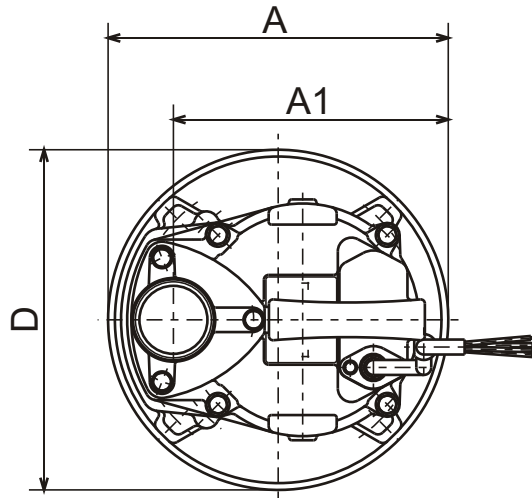

C.W.L. : Continuous running Water Level

**DIMENSIONS:USCS (Inch)**

Model	HP	NOM. SIZE	Pump & Motor						C.W.L.	Wt. (lbs.)
			A	A1	B	B1	D	H	W1	
KTV2-50	2.7	2"	9 13/16	7 15/16	16 9/16	14 1/2	9 13/16	17 7/8	4 3/4	55

**DIMENSIONS:METRIC (mm)**

Model	kW	NOM. SIZE	Pump & Motor						C.W.L.	Wt. (kg)
			A	A1	B	B1	D	H	W1	
KTV2-50	2.0	50	250	202	420	368	250	454	120	25.0