



TSURUMI PUMP

**MG-SERIES
GRINDER PUMPS**

DIMENSIONS

TOS50MG21.5 -62

**Guide Rail System
Model : TOSH-50 NPT**

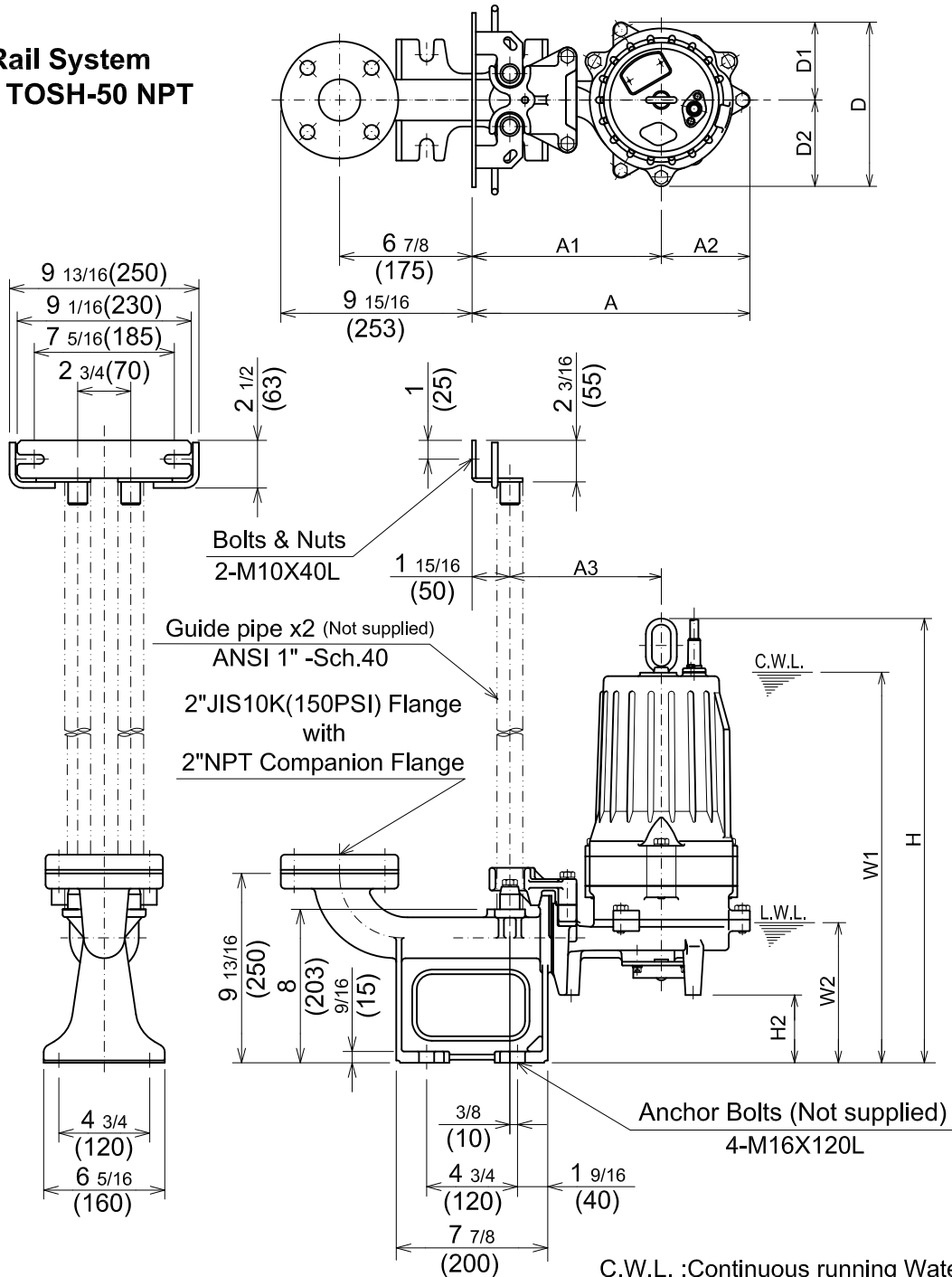

DIMENSIONS:USCS(Inch)

Model	HP	NOM. SIZE	Pump & Motor									C.W.L.	L.W.L.	*Wt. (lbs.)
			A	A1	A2	A3	D	D1	D2	H	H2			
TOS50MG21.5 -62	2	2"	14 7/16	9 13/16	4 5/8	7 7/8	8 9/16	4 1/16	4 1/2	23 1/8	3 9/16	20 1/4	7 1/4	79

DIMENSIONS:METRIC(mm)

Model	kW	NOM. SIZE	Pump & Motor									C.W.L.	L.W.L.	*Wt. (kg)
			A	A1	A2	A3	D	D1	D2	H	H2			
TOS50MG21.5 -62	1.5	50	367	250	117	200	217	103	114	587	90	515	185	36

*Excluding Cable & TOS