

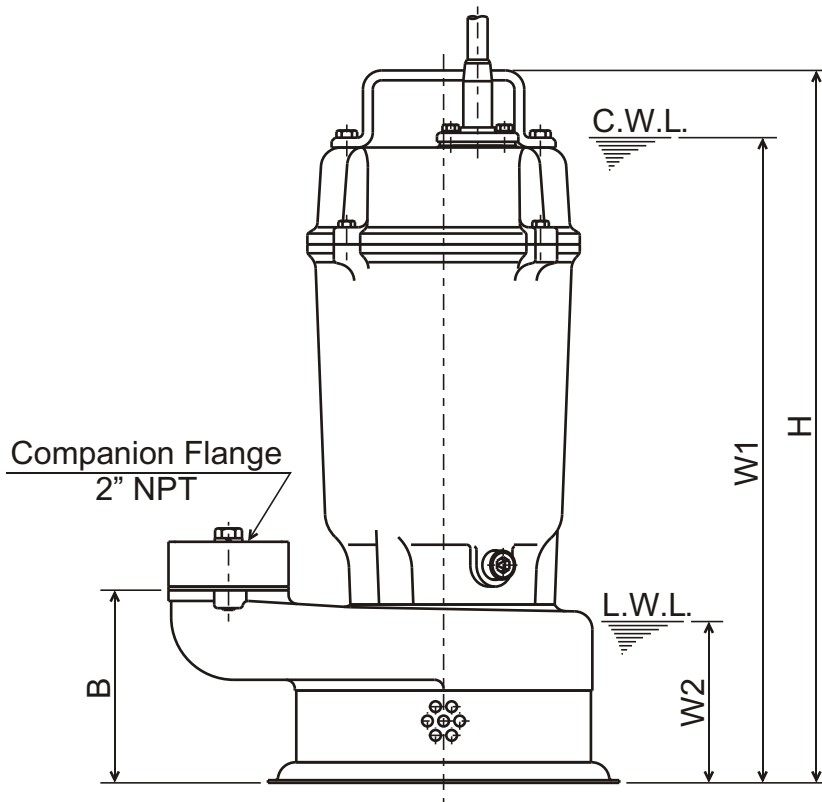

SFQ - SERIES
ALL 316SS- DEWATERING PUMPS

DIMENSIONS

50SFQ2.75-62

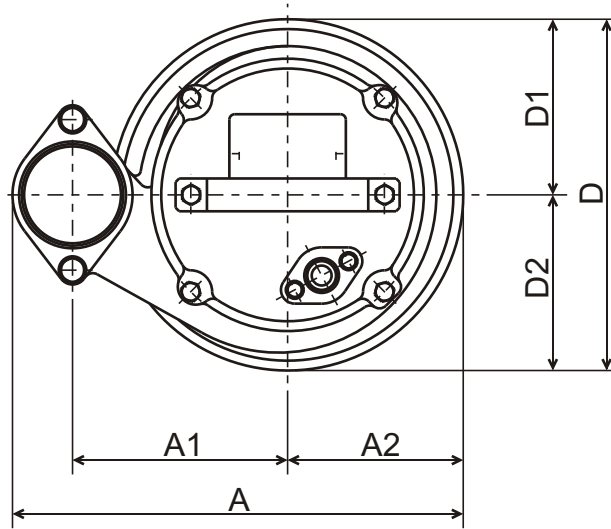

C.W.L. : Continuous running Water Level
L.W.L. : Lowest running Water Level

DIMENSIONS:USCS (Inch)

Model	HP	NOM. SIZE	Pump & Motor								C.W.L. W1	L.W.L. W2	Wt. (lbs.)
			A	A1	A2	B	D	D1	D2	H			
50SFQ2.75-62	1	2"	9 15/16	4 3/4	3 7/8	4 1/4	7 11/16	3 7/8	3 7/8	15 11/16	14 1/8	3 1/2	49

DIMENSIONS:METRIC (mm)

Model	kW	NOM. SIZE	Pump & Motor								C.W.L. W1	L.W.L. W2	Wt. (kg)
			A	A1	A2	B	D	D1	D2	H			
50SFQ2.75-62	0.75	50	252	120	98	108	196	98	98	398	360	90	22