

ELECTRIC PUMP EL1204UHH

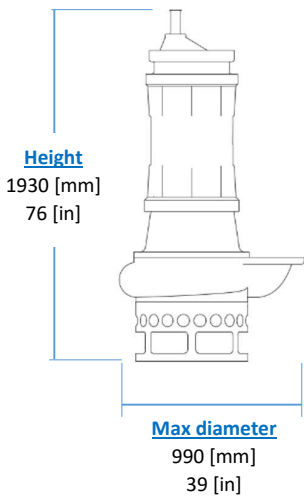
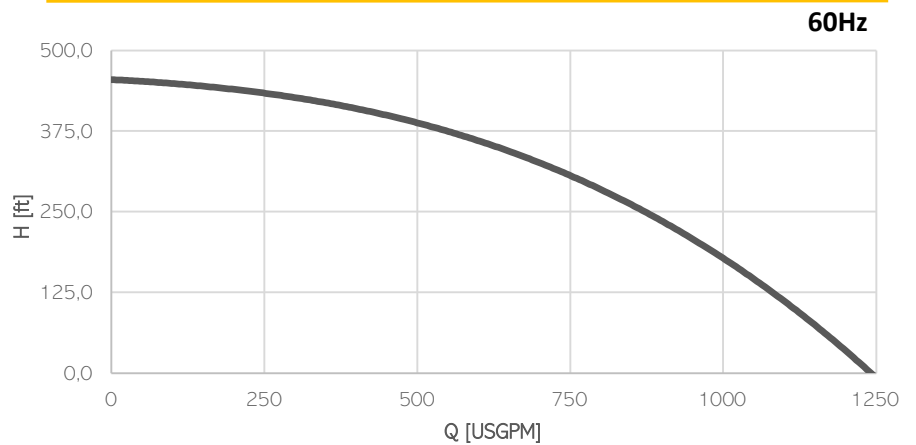

KG
Weight
(without cable)
1850 [kg]
4080 [lb]

Model	EL1204UHH
Brake Power [kW HP]	120 160
Electric Power [kW HP]	128 171
Frequency [Hz]	60
Efficiency [%]	42%
Number of Poles	4
RPM	1740
Voltage [V]	575
Rated Current [A]	144,0
Solid handling [mm in]	20 0.8
Discharge [DN-PN]	100-10

Materials

Part	Standard
Casing	Cast Iron EN-GJS800
Body	Cast Iron EN-GJL250
Wear Parts	High chrome EN-GJN-HV600 (CH6)
Minimum hardness [HB]	550
Main shaft	High tensile 39NiCrMo3
PH Range	5-10

Seals and lubricants

Version	-	MG	MS
Motor Side	-	MECHANICAL	MECHANICAL
Impeller Side	-	LIPS	MECHANICAL
Oil type	-	ISO32	ISO32

Electrical motor

Insulation class H

Cable

1 x SHD-GC cable 15m (50ft)

Operating Conditions

- Max liquid temperature 35°C
- Min Submersion depth 1700 mm