

HYDRAULIC PUMP HY85/180HC

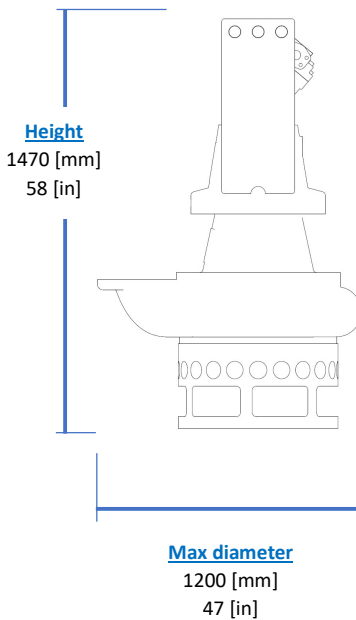
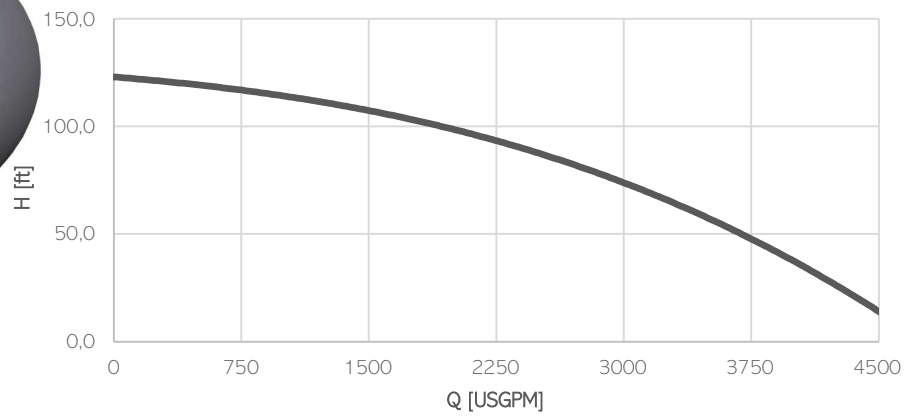
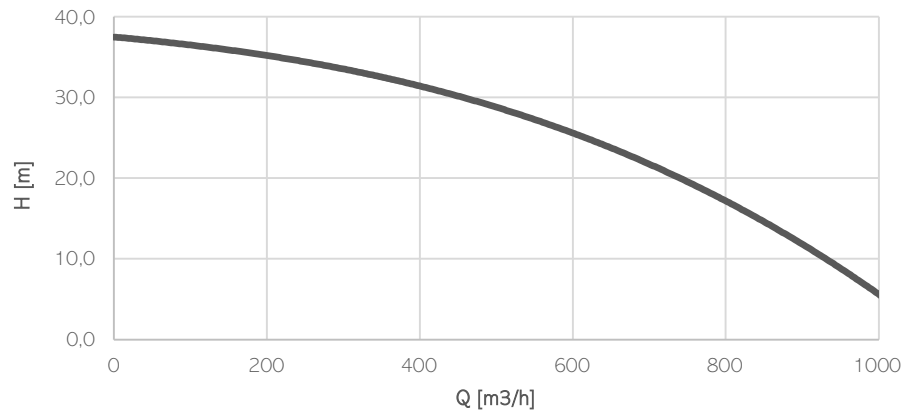

KG
Weight
1150 [kg]
2540 [lb]

Ports

- | Service line Ports: SAE J518 1 1/4in
- | Case drain Port: DIN3852 M22x1,5

Operating Conditions

- | Max liquid temperature 40°C
- | Min Submersion depth 550mm

Model	HY85/180HC
Brake Power [kW HP]	130 170
Efficiency [%]	43
RPM Max	1450
Motor Displacement [cc]	160
Oil flow rate max [l/min]	260
Nominal pressure [bar]	300
Max pressure [bar]	350
Solid handling [mm in]	90 3.5
Discharge [DN PN]	250 PN10

Materials

Part	Standard
Casing	Cast Iron EN-GJS500
Body	Cast Iron EN-GJL250
Wear Parts	High chrome EN-GJN-HV600 (CH6)
Minimum hardness [HB]	550
Main shaft	High tensile 39NiCrMo3
PH Range	5-10

Seals and lubricants

Version	HY85/180HC	MG	MS
Motor Side	LIPS	MECHANICAL	MECHANICAL
Impeller Side	LIPS	LIPS	MECHANICAL
Oil type	EP320	ISO32	ISO32